

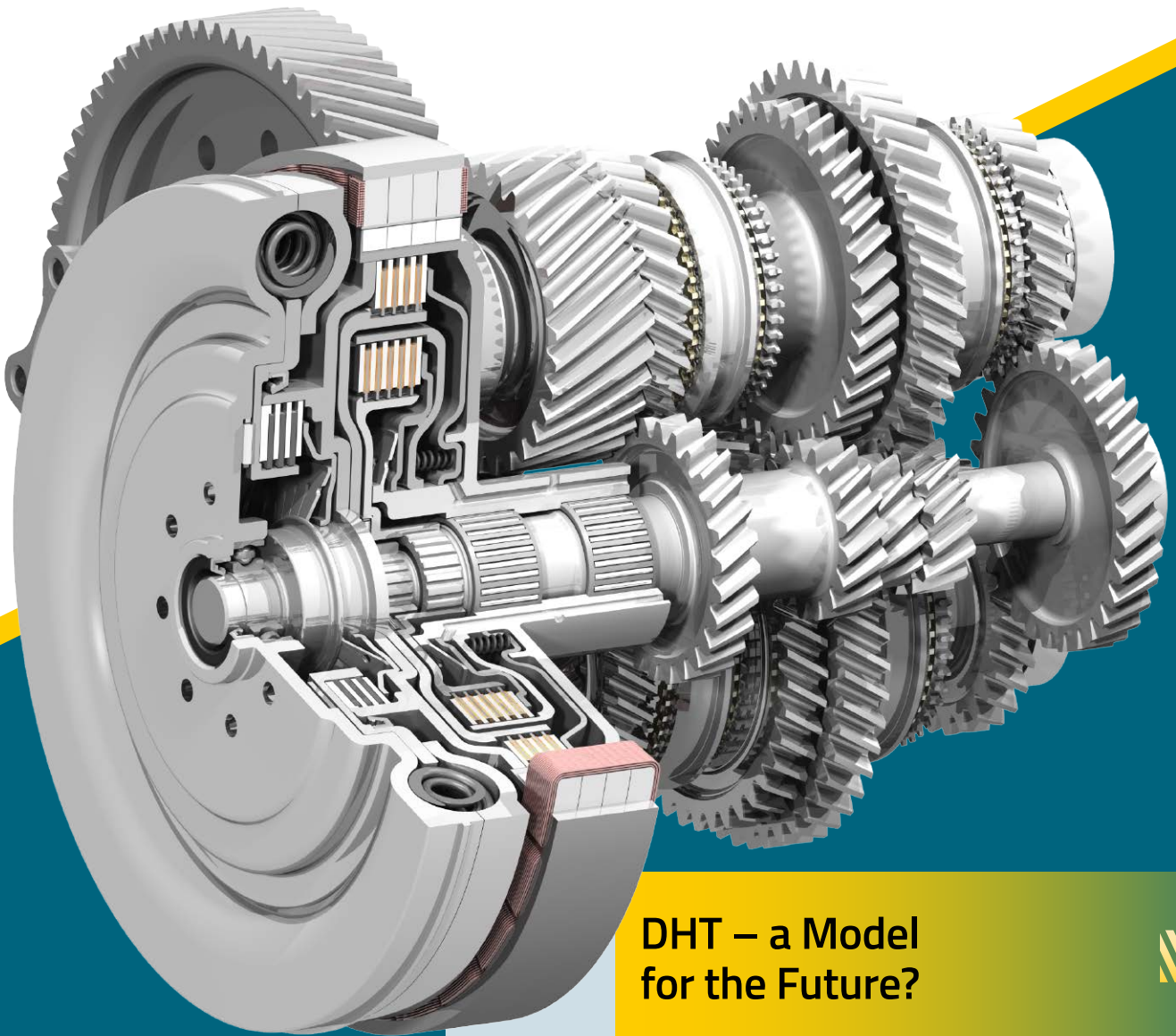

CTI *MAG*

The Automotive TM, HEV & EV Drives magazine by CTI

May 2016



**DHT – a Model
for the Future?**



**DCT Technology for
Low-torque Applications**



Interview with Larry T. Nitz
Executive Director Transmission &
Electrification, General Motors

DRIVING INSPIRATION

HOME OF TRANSMISSIONS

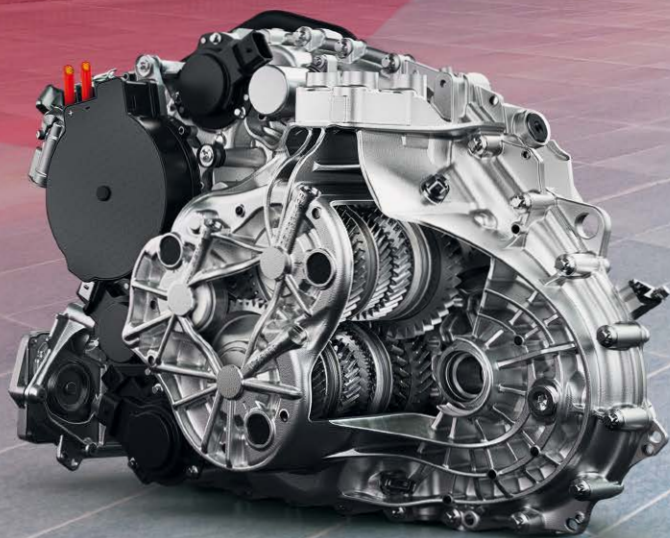

Visit us at
getrag.com/hybrid



 Follow us on Twitter

Innovations in motion

Experience the transmission technology of tomorrow. Be inspired by modern designs that bring together dynamics, comfort and highest efficiency to offer superior performance. Learn more about our hybrid transmissions from mild to plug-in. Discover a whole world of fascinating ideas for the mobility of the future.

GETRAG – Home of Transmissions

 **GETRAG**



CTI *MAG* Contents

- 6 **Expert Forum: DHT – a Model for the Future?**
CTI

- 8 **“We Have Created a Modular Dedicated Hybrid Transmission”**
Interview with Larry T. Nitz, Executive Director Transmission & Electrification at General Motors

- 10 **“In the Future, Everything Will be Hybrid”**
Interview with Gerald Killmann, Vice President R&D, Toyota Motor Europe

- 12 **DCT Technology for Low-torque Applications**
GETRAG

- 16 **Power-Shifting Made Easy for Stepped Automatic Transmissions**
IAV

- 18 **Modern Approach in the Design of Compact Axle Gears**
Drive System Design

- 20 **eTWINSTER – the First New-Generation Electric Axle System**
GKN

- 23 **Supplier of Sensors and Semiconductor Electronics for Transmission Applications**
IHS

- 26 **The Next Generation of Hybrid Transmissions**
Follow-up report, 14th International CTI Symposium – Automotive Transmissions, HEV and EV Drives,
7–10 December 2015, Berlin, Germany

- 30 **Management News**

CTI MAG

The Automotive TM, HEV and EV Drives magazine by CTI

Publisher/ Business Address:

Car Training Institute (CTI)

A division of EUROFORUM Deutschland SE
Prinzenallee 3, 40549 Duesseldorf, Germany
Tel.: +49 (0)2 11.96 86–30 00
Fax: +49 (0)2 11.96 86–40 00
www.euroforum.de
E-Mail: info@euroforum.de

Responsible for the publisher according to the German Press Law:

Michael Follmann

Print: ALBERSDRUCK GMBH & CO KG,
Leichlinger Straße 11, 40591 Düsseldorf

Cover photo: Institut für Fahrzeugtechnik,
Technische Universität Braunschweig

Layout: Hanno Elbert, rheinsatz, Köln

Print run: 3000 copies

Copyright

The articles in the CTI Mag are published by EUROFORUM Deutschland SE. Literary copyright to all articles, illustrations and drawings contained therein is held by the relevant authors. No part of the publication may be reproduced by any means, mechanical, electronic or otherwise, without the express prior permission of the publisher and authors of the articles and drawings. The authors accept sole responsibility for the content of the articles.

Dear readers,

Since its launch two years ago the CTI MAG has become one of the important information resources for reports from the industry on the design, development and manufacture of automotive transmission and drivetrain systems.

In our 6th issue we continue to provide you with latest insights on advancements of technical solutions as well as the second edition of our "Experts Forum": 5 experts share their thoughts about the future of DHTs, a new class of transmissions developed specially for hybrid drives. The term was introduced 2015 at the International CTI Symposium in Berlin.

With the Interviews with Gerald Killmann of Toyota Motor Europe and Larry T. Nitz of General Motors two acknowledged experts present a deeper look into characteristics, advantages and future of DHTs. Quite in keeping with our image and your expectations this issue is again covering an interesting range of topics for the global automotive transmission and drive community.

With this issue we start another column called "Management News" with which we inform about industry-related management changes and new faces. To keep the industry up to date we invite you to publish your company's management news as well, just let us know.

Thank you to all those who contributed to the current issue. We hope you enjoy reading the CTI MAG.

*Best wishes,
Your CTI Mag Team*

PS: The seventh issue of CTI Mag will be published in December 2016.

The submission deadline for articles and adverts is 4 October 2016.

To get all the details, just send a brief email to michael.follmann@car-training-institute.com.



Michael Follmann, Exhibition & Sponsoring Director CTI Transmission Symposia, CTI
Prof. Dr Ferit Küçükay, Managing Director, Institute of Automotive Engineering, TU Braunschweig, Chairman CTI Symposium
Sylvia Zenzinger, Conference Director CTI Transmission Symposia, CTI

Expert Forum

DHT – a Model for the Future?

By definition, Dedicated Hybrid Transmissions (DHT) use at least two sources of propulsion: an ICE, and at least one e-machine. Without either of these sources, they are not fully functional. DHTs can offer several modes, for example serial, parallel, power-split CVT mode, all electric and ICE mode. Optionally, they do not require an additional launch element. What are the prospects for Dedicated Hybrid Transmissions?

“Electric propulsion becomes an integral part of the system”

The term Dedicated Hybrid Transmissions (DHT) was defined during preparations for last year's CTI Transmission Symposium in Berlin. I had the honour of introducing DHTs there. The plenary discussion featured DHTs as a main topic, and in addition to two more plenary speeches, DHTs were also given their own section. Overall, it was great to see how well the definition of DHTs went down with the audience.

Solutions must be found to meet the legislative requirements to reduce fuel consumption and emissions. Since full electric vehicles cannot provide the range and speed of recharging most customers demand, hybrid powertrains will be key technologies in fulfilling customer expectations and legislative requirements. The biggest challenges for hybrid systems in this context are cost and weight. Increasing production volumes not only result in scale-up effects, but will enable the development of new, integrated solutions providing reduced costs and weight.

This is exactly what DHTs provide; the electric propulsion source becomes an integral part of the DHT to fulfil overall functionality. Thus, I am confident that DHTs will gain in importance in tomorrow's powertrains.



Dr Robert Fischer,
Executive Vice President,
Engineering and Technology
Powertrain Systems, AVL List

“DHTs will have a long-term place amongst all transmissions”

Over the next decade, we will continue to see advancements in conventional, electrified conventional and DHTs. The opportunities that DHTs have in optimizing both electric drive and engine efficiency are becoming clear to the industry. In the past, focus had been on optimizing engine efficiency, and electric driving was seen as an opportunity to keep the engine in its minimal consumption condition – OFF. Today, customers have made it clear that electric driving is highly valued, and engine-off elasticity is a valuable driving experience. At the limit, DHTs like the Voltec system in the Chevrolet Volt enable complete electric driving.

DHTs, when used as HEV or PHEV, offer consistent performance across battery SOC and temperature. Integration is key to pushing these transmissions to the leading frontiers of cost and perceived quality. Integration of motors, inverters, gearing and controls inside the transmission offer cost optimization opportunities and simplicity in application. Our customers are now realizing GM's scale advantages in manufacturing, and dedication of a complete manufacturing system to the DHT is happening.

The opportunity for DHTs to deliver customer-pleasing and consistent drive quality, a 'liquid' electric drive experience, flexibility in application and maximum system efficiency lead me to believe that DHTs will have a long-term place amongst all transmission types.



Larry Nitz,
Executive Director
Transmission & Electrification,
General Motors

“Future-proof hybrid technology requires adaptability”

We welcome the DHT definition, as it supports our common striving for uncompromised hybrid powertrains in terms of efficiency, weight and size. A major driver for future transmission architectures is the cost and availability of energy carriers. In longer-term forecasts, there is some volatility in terms of battery price, energy density and infrastructure on one hand, and fossil fuel prices or opportunities for CO₂-neutral fuels on the other. Consequently, appropriate transmission architectures should offer the possibility to scale and modify electrification and transmission layouts according to a variety of possible demands.

Future-proof transmission technology ideally offers flexibility and scalability, while maintaining economies of scale across the product range. For current and near-future requirements, GETRAG favours ‘torque split’ hybrid transmissions. Their architecture allows package-neutral and scalable electrification from 15 up to >75 kW, covering a wide range of applications. We do expect ‘downsized’ plug-in hybrid drives with a more dominant role for the e-machine longer-term. They may be laid out according to the DHT definition, like the GETRAG



Boosted Range Extender concept presented in 2009, or also in a parallel or torque-split layout. Layshaft transmission technology enables a flexible evolution path to future hybrid transmissions with optimal efficiency in any configuration.

Didier Lexa,
Chief Technology Officer,
Getrag International

“We see hybridisation as the evolution of conventional powertrains”

Nissan puts emphasis on the evolution of conventional powertrains and the growth of zero emission vehicles. Integrating some electrification into the conventional powertrain seems to be inevitable in the course of its evolution. However, electrification does not necessarily mean a high-voltage system is needed.

To have a chance of implementation and longer-term survival, any kind of electrification added to the engine or transmission must be cost-effective over the life cycle. For example, integrating a motor-generator for regeneration capability promises to improve fuel efficiency considerably, and cannot be achieved with non-electrified solutions. It is a challenge to develop an optimal solution in terms of packaging, weight and cost by using add-on technologies. Therefore, not just the electrical devices but all other systems and components within the powertrain should be re-designed and optimized for effective integration.

In our opinion, these solutions can be seen as part of the ongoing evolution of conventional powertrains. They do not lead to a ‘dedicated’ hybrid category. Between evolutionary conventional powertrains and zero emission solutions, we do not intend to pursue intermediate solutions.



Toshihiro Hirai,
Corporate Vice President,
Alliance Global Director for
Powertrain Engineering Division,
Nissan Motor Company

“The future belongs to the DHT”

Most 1st generation hybrid drivetrains for passenger cars, especially in European vehicles, are based on conventional drivetrains, with an electric powertrain added in a parallel architecture. This makes it possible to implement most of the advantages such as start/stop, recuperation and electric driving in low-power mode. Conventional and hybrid vehicles still use a modular architecture so that both types of vehicle can be realised in a flexible and variable manner.

Pure ICE-driven vehicles will no longer be capable of fulfilling future emission regulations. From this point of view, there will be less need for the flexible drivetrain architecture described above. Dedicated hybrid transmission systems with integrated electric motor(s) are more compact, more variable and, where large volumes are concerned, even cheaper than modular hybrids with a parallel architecture.

In the late 1990s Toyota, as the pioneer of volume production development of hybrid vehicles, used this kind of architecture in their Prius right from the start. Since then several proposals have been made by OEMs, Tier1 suppliers and ESPs. IAV has also developed a power hybrid as a dedicated 4-speed P2-hybrid for a B-class vehicle that combines highest performance with low fuel consumption and a very compact package.



Prof. Dr Burghard Voß,
Senior Vice President
Transmissions and Hybrid Systems,
IAV

Interview

“We Have Created a Modular Dedicated Hybrid Transmission”

With just a few changes to its architecture, the 2nd generation Voltec hybrid drive comes with added value in terms of increased electric range, improved NVH and new hybrid operation modes. Customer data and feedback played a crucial role in designing the Gen 2 Voltec, says Larry T. Nitz, Executive Director Transmission & Electrification at General Motors.

Mr. Nitz, the first generation Voltec was a bold step forward in range extender technology. What customer feedback did you consider when designing the second generation?

When we designed the first generation, we made many assumptions about what customers would like about this new kind of propulsion. We made assumptions about how they would use the vehicle, the EV capability, its charging behaviour, the use of the engine, NVH etc. The first Volt is probably one of the most studied automobiles in history. Throughout the car's lifecycle, we studied usage by collecting data using OnStar, which enables anonymous data collection, if customers agree. Two-thirds do, so we got a lot of data to learn from. We learned that customers really love the EV capability, the idea of not having to refuel that often. Most of these customers go over 900 miles between fill-ups. The other thing they love is this “liquid” driving feel, the immediate torque delivery, the “guilt-free” performance and driving pleasure.

You increased the all-electric range of the new Volt, for example – for what reason?

For the 2nd generation, we specifically went after the things customers liked – and gave them 40 percent more range. To do so, we used a slightly bigger battery; we used the battery a little more deeply than we did in Gen 1. Both battery usage and the other components of the powertrain are more efficient, while the whole system is less complex, and hence less costly. Cost-down is important, it's critical for any EV application. With Gen 1, we went out into the great unknown. Now we know the requirements, and we are making improvements all the time in cost effectiveness as well as continuing to deliver on our customer promise. Another thing we gave our customers is more performance – about 20 percent more at low speeds. Because the feedback was that they really like this “get up and go”.



Larry T. Nitz, Executive Director Transmission & Electrification, General Motors

How would you modify the EV architecture if battery prices and energy density were to improve by, say, a factor of 2?

With the current Volt, many people do 80 percent of their driving in all-electric mode. With an electric range of 53 miles in the second generation, I think we improved that by another ten percent. The energy density of our battery improved 4 percent during the first generation, then another 12 percent with Gen 2. If battery prices came down significantly, we would probably increase electric range further, as long as it is affordable and helps efficiency. And we would further reduce battery packaging and weight.

More electric range leads to less engine operation. How do you keep it in good shape?

We created what we call "engine maintenance operation". If the engine does not run for around three months, we force a start. However, this may come at an inopportune time, so we give the customers two times to say no. But the third time, the engine starts. It does a full engine warm-up to evaporate water, circulate the oil etc. We also make sure the fuel stays in good condition. Firstly, we have a completely sealed fuel system, so there is no oxygen migration. Secondly, we have a fuel maintenance mode. We want to keep the average age of the fuel at one year or less. If the fuel gets too old, the system starts the engine to burn some of it. In practice, this does not happen too often with the current Volt. With an EV range of 53 miles, it is certainly more likely to happen but I think we have that very well protected.

What changes did you make in terms of engine efficiency?

In the Gen 1 Volt, we used a small, naturally aspirated four-cylinder engine. The battery was full-sized with 110 kW, and the engine literally half-size with 55 kW. There was no turbo and no intercooler. The challenge was to maintain that great EV feel and low noise and vibration when the engine is on. What we found was that that the engine was actually a little small in some situations. If you drove hard in mountainous areas for example, you could fall back because the little engine was working pretty hard to fill the occasional energy void of the battery. People noticed that. There was no concern in normal driving, but not everybody lives in flat regions. So in Gen 2 we moved from 1.4 to 1.5 litres and from 55 to 75 kW. The benefit is that the engine can keep

up a lot better and run with much better NVH characteristics. Also, making the engine larger allowed us to reduce the size of the battery buffer we needed, which gave us some of the added EV range. The engine is more efficient too: it is all aluminium with a higher compression ratio, yet it runs on regular fuel, whereas the first generation needed premium. We added a cooled EGR, and wider authority cam phasers to enable an Atkinson-type cycle.

The new system architecture with two planetary gearsets suggests more complexity in terms of clutch actuation. How do you keep this efficient?

The Gen 2 Volt has two planetary gearsets and two active clutches. A normal automatic transmission may have three or four planetary gearsets and five clutches as a minimum. So the complexity of just two clutches is actually a sigh of relief! Only one clutch is open at any given time, held open by a spring; sometimes no clutches are open. Our hydraulic system is all electric, we run an electric on-demand pump to control the two clutches and provide lubrication. We think the hydraulic system is quite simple and straightforward – much less complex, lighter and smaller than a normal AT. The real challenge lies in keeping the driving strategy efficient.

There is a considerable amount of powersplit operation in Gen 2. How does this affect your options to vary engine size?

The Gen 1 powertrain was actually designed specifically for a range extended EV. This configuration would not have made a great hybrid. In the second generation, we created modularity – and not just in terms of modular components. The new Voltec architecture can be a range extended EV, a plug-in hybrid or a hybrid. With just a few part number changes, we can take this exact powertrain and couple it with various engines in different vehicles. It is currently used for the Volt 2 with the 1.5 litre engine, and with slight changes in the Chevrolet Malibu Hybrid, combined with a 1.8 litre engine. For this application, we simply change the rotor configuration in one electric drive to balance the larger engine. There is no other architecture in the world that I am aware of, at this level of modularity. Most people think DHTs are so dedicated to a specific mission that they cannot be modular. Yet what we have created is a modular dedicated hybrid transmission.

Interview: Gernot Goppelt





Interview

“In the Future, Everything Will be Hybrid”

One of the key topics at the 14th International CTI Symposium was DHT, a hybrid transmission designed exclusively for dedicated hybrid use. Toyota has favoured this approach for nearly 20 years. We spoke to Gerald Killmann, Vice President R&D, Toyota Motor Europe, about the future of hybrid powertrains.

Toyota is a pioneer and major supplier of DHTs. What makes Toyota’s Hybrid System different from other architectures?

DHTs are flexible on principle in terms of motor variations, torque range, power range etc. The Toyota Hybrid System is specifically configured, meaning the three power units – combustion engine, generator and motor – all match each other in order to deliver the required torque and dynamics with the highest system efficiency. Obviously, you can go for more universal systems in terms of compatibility with engines. But then the transmission would be over-dimensioned for many applications, making the powertrain heavier, less dynamic and more expensive. So instead, we focus on a clearly dedicated approach that enables sufficient production volume for an affordable product.

The Toyota Hybrid System is an impressively simple mechanical design. How much simplicity would you give up to enable additional functional features?

Toyota’s base philosophy, Kaizen, means continuous improvement. There will never be a single, ultimate solution. We are constantly working on improvements. We optimized several 1st generation Prius components – such as the motors – for generation II, and added a secondary planetary gear set for the 3rd generation, so we are constantly improving. In high performance hybrids with a longitudinal layout, like the Lexus GS450h or LS600h, a two-stage motor speed reduction device adds high-speed electric motor flexibility for speeds of up to 250 km/h, by switching the torque path in the device’s planetary gearset. Put simply, we are open to additions and modifications providing there is a reasonable customer advantage.



Gerald Killmann, Vice President R&D, Toyota Motor Europe

The powersplit architecture is somewhat restricted in terms of high-speed efficiency ...

The powersplit architecture is definitely most efficient at lower to medium speeds, and loses some of its advantage at high speeds. To some extent this reflects regulations like those in Japan, where vehicle speeds are limited to 180 km/h (112 mph). The smaller powertrain versions of our hybrid vehicles are designed for maximum speeds of about 180 km/h. The technical reason is mainly the maximum permitted electric motor speed within the powersplit system, not the power. That means you can reach that speed not just on the flat but uphill too, since there is enough hybrid system power to maintain your speed. Making a special effort to enable high-speed driving is certainly appropriate for performance hybrids like the GS450h and the LS600h. For less performance-oriented models, we need to carefully consider the balance between market requirements (for example how many countries this is relevant for), and the costs that all customers have to bear, regardless of which market they are in.

Toyota's hybrid history includes both parallel and serial hybrid drives. What do you think about mixing different hybrid modes, as some potential DHT suppliers want to do?

We very much appreciate the rising interest in hybrid technology, and the fact that more products are emerging. This will help competition, inspire engineers and lead to even better products. We are working very hard on our current system, and at the same time analysing new ideas within our company. We will definitely pursue the THS architecture further. I don't want to rule out the possibility of looking at one or another of the new system approaches. That might be either on the lower voltage or the very high voltage side, providing it makes sense in terms of cost and customer value. At Toyota, we started down the hybrid road many years ago. Since the beginning, we were convinced that a variety of powertrains is needed. So we will keep conventional diesel and gasoline powertrains while definitely expanding our hybrid portfolio too – including bringing hydrogen fuel cell vehicles to market. Of course, vehicle types and the markets in which we apply the different powertrains will vary. Our key objectives are highest quality, highest reliability and a clear customer benefit.

You still rely on NiMh batteries for some of your hybrid models. Why is that?

In our experience, NiMh batteries are extremely reliable. They withstand the tough temperature ranges in automotive applications, from extremely low to very high temperatures. We have a clear understanding of how to ensure reliability throughout vehicle lifetimes. And our battery factories – which are a joint venture with Panasonic – are very efficient at producing batteries that can do that. For us, using this technology to benefit our customers in terms of quality and vehicle cost is a natural thing to do. We will continue to use NiMh, but will also bring in Li-Ion in parallel. The Prius Plus is an example: in the seven-seater version we fit a Li-Ion battery between the front seats; in five-seater models we can fit a slightly larger NiMh battery under the boot, without sacrificing carrying capacity. Package is a key driver, along with weight and cost.

How important are liquid energy carriers for your powertrain road map?

High energy density is a key requirement for long distance driving. We believe battery technology will evolve, but there will always be restrictions in terms of durability and low temperature performance. So from this perspective, we see battery-electric vehicles more in short-range and urban applications. Yet on the other hand, we also need vehicles

for long-range driving. High energy density is a key requirement for passenger cars there, and more important still for heavy-duty applications. But fossil fuels are bound to run out, so we are looking very closely at alternatives. In our opinion, hydrogen is one of the key opportunities to achieve zero emissions and zero CO₂, providing it's produced with renewable energies. So we're putting a great deal of effort into what we call the Future Hydrogen Society, which is an opportunity to contribute to keeping global warming at reasonable levels.

What does the path to future hybrid applications look like?

In the future, everything will be hybrid. Some people will use 48 Volt, Toyota will definitely rely on the THS. There will be plug-in hybrids, fuel cell hybrid drives – it's all hybrid except for battery-electric vehicles for short range use. With 48 Volt, the question is how much hybrid benefit is really there, because the effect for the customer is smaller than with a full hybrid. That's exactly what we experienced with the Toyota Crown in Japan in 2001, with 36 Volt and a secondary battery. Customers didn't feel the hybrid benefit. It had start/stop, and to a certain extent enhanced launch and torque assist from a belt-driven generator. But it wasn't really a success. As a result, even today we are very cautious about the benefits of this type of architecture. Hybrid architectures make most sense when there are both clear benefits in terms of CO₂ reductions, and a perceptible customer benefit.

Interview: Gernot Goppelt



DCT Technology for Low-torque Applications

Besides offering more comfort, modern automatic transmissions should help for lower fuel consumption. The new dual-clutch transmissions 6DCT150 and 6DCT200 with cascaded first gear layout enable efficient automation even in the high-volume segment of small passenger cars. In the first reference application, the 6DCT150 enabled fuel consumption benefit of 5 % in comparison to a five-speed manual transmission in the NEDC.

- Roland Nasdal | Senior Manager Product Development 6DCT150/200, Getrag Ford Transmissions GmbH
- Sascha Mierbach | Platform Director 6DCT150/200, Getrag Ford Transmissions GmbH
- Udo Bernhardt | Transmission Architect 6DCT150/200, Getrag Ford Transmissions GmbH

Market situation

The increasing use of automatic transmissions in small passenger cars requires new transmission concepts with high efficiency in every aspect. The respective challenges exist in the area of engine compartment package as well as in increasingly strict limits for CO₂ emissions, resulting in increasing use of downsized engines. However, turbocharged three-cylinder engines with 0.8 to 1.5l displacement will co-exist with low-cost conventional four-cylinder 1.2 to 1.6l naturally aspirated engines for a while. This market situation leads to a number, in some cases conflicting requirements: The transmission should be small and lightweight, but offer a sufficient number of speeds for downsizing and downspeeding concepts. The design of the ratio of the launch gear and of the launch element must be compatible with low launch torque typical for entry-level engines. In conjunction with downsized engines, the size and inertia of the launch element and the transmission are of major interest, since the damper device will be larger and require more package space.

The new dual-clutch transmissions 6DCT150 and 6DCT200 by Getrag offer a number of new features to fulfil these demands. These are primarily a full on-demand actuation of the shifting and the wet clutch, as well as a gear set design featuring a cascaded first gear.

Wet dual clutch and pump actuation

The transmissions 6DCT150 and 6DCT200 will be used in a vehicle segment, where engines do not offer enough torque to compensate low transmission efficiency by means of longer ratios and excessive downspeeding. For low-cost and low-torque applications, transmis-

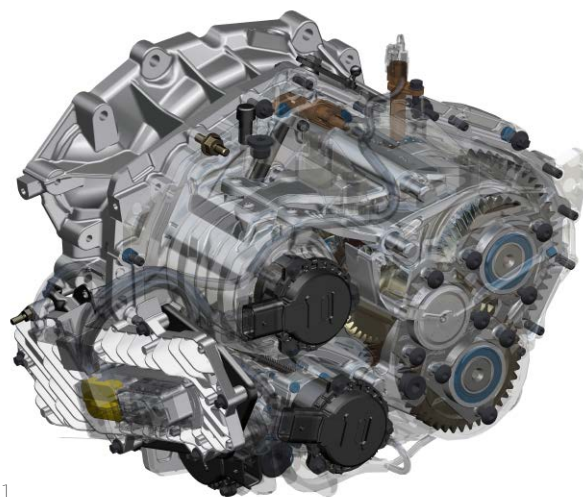

Figure 1
Low power-demand
with on-demand actuation

sion architectures with little parasitic losses come even more to the fore. One key measure to preserve the excellent efficiency of layshaft transmissions when being automated is very low power demand for shift and clutch actuation.

The new Getrag transmissions with on-demand pump actuation have an electrical power demand of 31 W for the entire actuation in average over several compact to mid-size applications in the NEDC, and 33 W in the WLTP, Figure 1. This value comprises the actuation of the shift drum for the two sub transmissions, actuation of the two pump actua-

tors for the wet clutch and the oil supply for clutch cooling. As a result, power demand is on a level that can usually only be achieved with a dry dual-clutch transmission^[1].

The actuation concept in combination with the wet dual clutch is carried over from the 7DCT300^[2] to the new smaller 6DCT150 and 6DCT200 dual-clutch transmissions. For applications with lower torque demand and lighter vehicles, the electric power demand can be even lower and considerably below 30 W in the driving cycle. Unlike the 7DCT300, only one instead of two electric motors is used for the shift system, Figure 2. The wet dual clutch significantly contributes to the compact overall package and high flexibility in terms of shift behaviour and launch. Moreover, it has a lower inertia than a dry dual clutch and is capable to handle high torque output, typically delivered by turbocharged downsized three-cylinder engines. At the same time, it is capable to handle high friction energy during launch, caused by low available torque from small naturally aspirated engines at higher loads and in heavier vehicles.

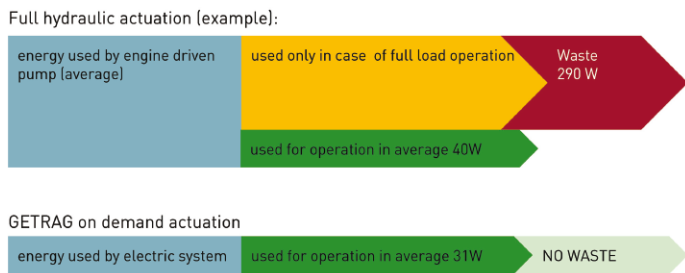

Figure 2 Small package thanks to wet dual clutch, one shift drum and cascaded 1st gear

Cascaded first gear

The second key measure, reducing weight, size and inertia, is the cascaded first gear design. The design is based on a partial "bridging" of the sub transmissions. In case of the 6DCT150 and 6DCT200, the 1st gear is created virtually by coupling the 5th and 6th gear, while abandoning the redundant largest gearwheel. As a result, a "physical" five-speed transmission is enabled to offer six forward speeds, adding just one shift element. The resulting very compact gear set, Figure 3, combined with the wet dual clutch, substantially reduces package size as well as inertia. In order to form the cascaded gear, the 1st and 2nd gear

share one gear-wheel. For the 1st gear, the flow of forces runs over the gear-wheel of the 2nd, 5th and 6th gear.

As a side effect, the multiple use of gears for the cascaded gear results in a small amount of additional friction. However, this has no measurable effect on real-life and cycle consumption, because the first gear is only used during launch, in a very short time, at very short distance. This is more than offset by lower inertia as well as much lower weight and smaller size. A further principal constraint could be seen in the fact that the cascaded gear ratio cannot be chosen independently. Still, the overall ratio spread can be varied from 4.5 to 8.0.

Enhanced drivability

In the 6DCT150 architecture, the ratio step from 5th to 6th gear corresponds to the step from 1st to 2nd gear. Typically, the 1st gear ratio will be 15.5 while the conventionally designed 2nd gear ratio will be 11. This factor of 1.41 is rather small in comparison to conventional layouts. However real-life drivability benefits from this, because the relatively small ratio step enables a more comfortable upshift from 1 to 2 and more spontaneous torque supply in the 2nd gear. Moreover, this layout allows to avoid downshifts to the 1st gear in re-launch situations at low-speed driving. This is especially helpful for turbocharged engines to avoid insufficient charging pressure. Car clinics and customer feedbacks have confirmed positive perception of this layout. Shift quality and relaunch capability were perceived to be superior.

In conjunction with the wet dual clutch that can be tuned for different applications and environments, the launch capability was proven even under severe conditions such as 4000 m of height (13,000 ft) and 12 % grade, where engines lose a lot of power. Compared to an inherently fixed torque converter, the dual clutch allows to apply its behaviour to any engine and condition to ensure optimal launch behaviour. The active on-demand clutch cooling robustly supports the associated longer slip phases.

Unlike the 7DCT300, the smaller 6DCT150 and 6DCT200 rely on just one shift drum rather than two, reducing the total amount of electric motors to four instead of five. Especially with regard to entry-level cars, this reduces weight, cost and package space. The only limitation is that direct 6 to 3 downshifts are not possible. However, this has no effect on real-world driving, as cars in lower torque classes tend to be calibrated for comfort rather than sport. The 6 to 3 downshift would

cause inconvenient engine speed and noise levels with small engines. In addition, it takes rather long to bridge the engine speed gap and reach adequate engine speed with low-torque engines. Actually, real-world driving benefits from a sequential shift strategy: In conjunction with low-torque engines it guarantees small shift steps and fast gear shifts, enabling steady increase of wheel torque.

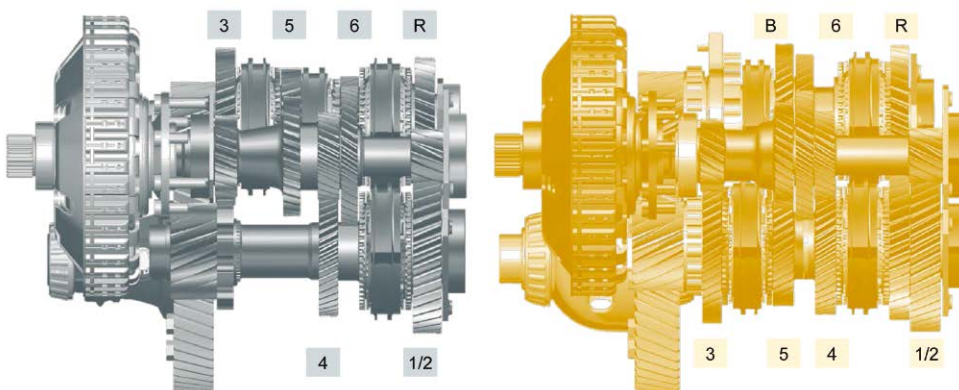

Figure 3 Gear set comparison of 6DCT150 (grey) and 6DCT200 (yellow)

Common parts

The main difference between the 6DCT150 and 6DCT200 is the main centre distance of 170 mm for the 6DCT150 and 183 mm for the 6DCT200 and the input torque of 190 and 230 Nm respectively, Figure 4. The larger main centre distance is necessary, because the differential position is moved towards the firewall, when three-cylinder engines with up to 500 cm³ per cylinder with larger flywheels are used. In addition, the positions of the park lock system and the transmission control units are different. Besides these application-specific differences, both transmissions share the same architecture. 6DCT150 and 6DCT200 use many identical components, namely differentials, synchronisers and main bearings, Figure 5, and a number of common parts with the 7DCT300^[2], Table 1, like the actuation motors, pumps, and the Transmission Control Unit (TCU).

The concept of the pump actuation^[3] offers substantial advantages in terms of package size and flexibility. Other than with conventional valve hydraulics, the pump actuators can be positioned in a way to

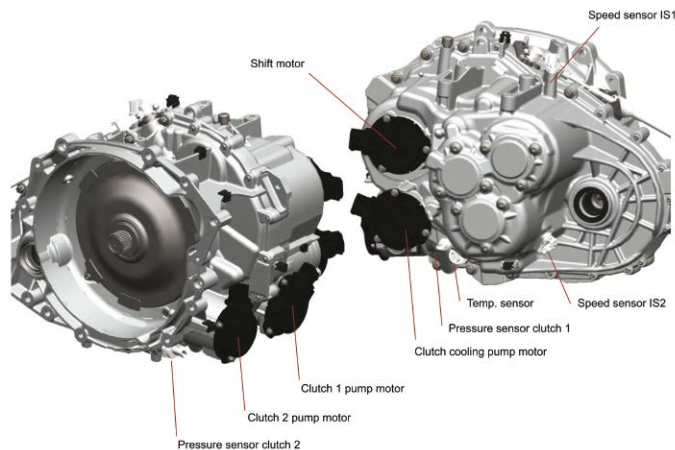

Figure 4 Different centre distances for different engine types

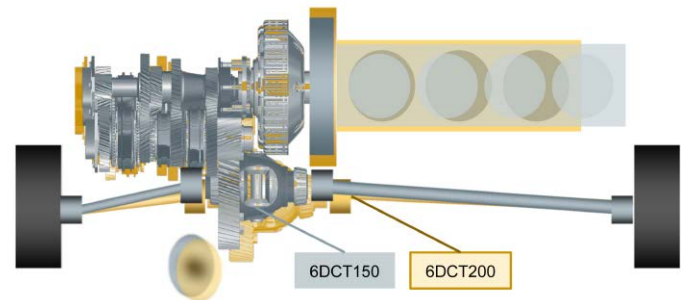

Figure 5 Common parts of 6DCT150 (left) and 6DCT200 (yellow)

Smart Modularity Design

Subsystem	7DCT300	6DCT150	6DCT200
Clutch	DC300 Clutch	Common with DCT300	Common with DCT300
Clutch Actuator	Pump actuator	Common with DCT300	Common with DCT300
Cooling / Lube	E-motor driven pump	Common with DCT300	Common with DCT300
Oil	Fuel economy and cost optimized lubricant	Common with DCT300	Common with DCT300
Hybridization	E-motor in transm. housing or axle-split hybrid	Hybridization feasible	Hybridization feasible
Software	7DCT300 SW features	7DCT300 + SW for single drum	7DCT300 + SW for single drum
TCU	7DCT300 Standalone TCU	7DCT300 Standalone TCU for first application	New Standalone TCU for package, carry back 6DCT150
Synchronizer	Carbon lining, geometry as 6DCT250	Carbon lining, package optimized	Common with 6DCT150
Bearings	Snap ring fixation	c/o 6DCT250	Common with 6DCT150
Shift System	Dual EM shift drum	Single EM shift drum with integrated drive gears	Single EM shift drum with integrated drive gears
Gear set	7 speed	6 speed bridge	6 speed bridge
Park Lock Actuator	Mechanical / by wire	Mechanical	Mechanical / by wire

Smart Modularity Design = Reduced Development Effort

match any required package envelope. Moreover, 6DCT150 and 6DCT200 (as well as the 7DCT300) can be electrified from mild hybrid to plug-in hybrid, again sharing a high percentage of common parts [4]. The 6HDT200 in a 48V version was presented on the IAA 2015 along with the 7HDT300 in a 48V and 400V version.

NEDC fuel consumption

The newly developed Getrag dual-clutch transmissions 6DCT150 and 6DCT200 were designed for low-torque applications being typical with inexpensive and/or small vehicles. They set a new benchmark for cost, package, fuel efficiency and weight. For a first application with the 6DCT150 Getrag could verify a fuel consumption benefit of 5 % in comparison to a five-speed manual transmission in the NEDC. Compared to a modern torque converter automatic transmission, a consumption benefit of 10 to 15 % is possible. The two small members of the Getrag DCT family are a consequent answer to the question, how small and inexpensive passenger cars can be automatized in a highly efficient way.

References

- [1] Faust, H.; Buender, C.; DeVincent, E.: Dual clutch transmission with dry clutch and electro-mechanical actuation. In: ATZworldwide 112 (2010), No. 4, pp. 30-34
- [2] DeVincent, E.; Blessing, U. C.; Herdle, L.: Light front-transversal dual-clutch transmission with high efficiency. In: ATZworldwide 115 (2013), No. 12, pp. 4-9
- [3] Castan, R.: On-demand actuation concept for a new DCT generation with wet clutches. 13th International CTI Symposium Automotive Transmissions, HEV and EV Drives, Berlin, 2014
- [4] Blessing, U. C.; Meissner, J.; Schweiher, M.; Hoffmeister, T.: Scalable hybrid dual-clutch transmission. In: ATZworldwide 116 (2014), No. 12, pp. 46...51

Table 1 Common-parts strategy within GETRAG 3rd generation DCT family

Bühler
Motor



»» fast forward solutions

bFlow

► New flexible pump solutions platform ...



COOLANT



OIL

bFlow O: Electric Transmission Oil Pumps

- Start/Stop & Mild Hybrid
- Hybrid & Advanced Functions
- Coasting

bFlow C: Electric Auxiliary Water Pumps

- Turbocharger Cooling
- EGR Cooling
- EV Car Thermal Management

► Contact North America

Mr. David Griffith
Key Account Manager Automotive
David.Griffith@buehlermotor.com
+1 919 380 3334

► Contact Europe

Mr. Herwig Moser
Director Powertrain Solutions
Herwig.Moser@buehlermotor.de
+49 911 4504 1199

»» www.buehlermotor.com

We look forward to seeing you at:

CTI Symposium USA | Novi, MI

Suburban Collection Showplace, #40 | May 11 – 12, 2016



Power-Shifting Made Easy for Stepped Automatic Transmissions

An IAV tool transforms complex transmissions to the generic interfaces of the generic power-shift sequence control – simplifying calibration and speeding up modeling

- Roland Serway, Head of Software and Algorithm Development for Transmission and Hybrid Systems, IAV Automotive Engineering
- Dr Uwe Mettin, Development Engineer Software and Algorithm for Transmission and Hybrid Systems, IAV Automotive Engineering
- Alexander Lampe, Development Engineer Software and Algorithm for Transmission and Hybrid Systems, IAV Automotive Engineering

Developing algorithms and calibrating torque converter automatic transmissions is difficult and costs a lot of development time, particularly in view of the rising number of gears. The engineers have it much easier with dual-clutch transmissions (DCT) which always have the same clutch structure and can therefore be calibrated in a straightforward manner. IAV has developed a method that transforms the complex structure of torque converter automatic transmissions in a way that makes you think you are dealing with a DCT. As a result, every stepped transmission can, in principle, be controlled with the same algorithms and calibration.

Essentially, dual-clutch transmissions are always structured in the same way: Two clutches connect the input shafts and their gear ratios with the drive. The situation is far different with torque converter automatic transmissions. There are many different versions with completely different structures which, for example, vary in the number of clutches and the internal connection of their shafts. This is why, in the past, each gear shift had to be calibrated separately, if necessary with special software – in spite of them all performing similar power-shifts. DCTs, however, have a simple clutch structure and gear shifts are not realized differently as there is only one clutch for the even gears and one clutch for the odd gears.

Transformation to Dual-Clutch Transmission

This sparked the idea at IAV to use the generic power-shift sequence control of a DCT for torque converter automatic transmissions too,

and transform the complex automatic transmission structure to the generic interfaces of the power-shift sequence control on the basis of algebraic equations. This process is by far not trivial because a mathematical forward and a mathematical inverse transformation are needed. Besides this, the interfaces and the software structure for a generic power-shift sequence control are not quickly at hand. In principle, the IAV transmission experts need to transform the specific torque converter automatic transmission in a way that suggests its clutches were not in the transmission but located directly on the crankshaft – just as they are in a DCT. However, whereas engine speed here always equates to transmission speed, matching them up for a torque converter automatic transmission is anything but easy because of the internal shafts. On top of this, each gear change can involve a different clutch. A DCT is limited to a choice of two.

Structural changes at the press of a button

Working on an in-house development project, IAV has developed a method that successfully models a torque converter automatic transmission and transforms its complex structure to a DCT. It makes it possible to use the same software for a whole host of different transmission versions – from the DCT to the torque converter automatic transmission. It is even feasible to modify the structure merely at the press of a button: In a few minutes, IAV can turn a six-gear torque converter automatic transmission into a layout with nine gears. And all the calibrators need to know is which of the four basic gear shifts needs to take place at a specific moment. These are produced from



the different combinations of power-shifting and coast shifting of gears up and down, respectively. To apply the method, the user needs to know the torque converter automatic transmission's topology and key it into the IAV tool, but that is not particularly difficult. Basically, the shafts must be numbered to specify the clutches they are linked up with later on. Other input variables the method needs are the gear ratios of the gearwheels and the specific clutch type. Proceeding from the transmission motion equations, the program delivers a dataset that can be used for computing the coefficients for each gear change and determines the parameters for the control unit software.

As many as 1,000 gear speeds theoretically possible

The number of gears the specific automatic transmission has is irrelevant – in theory, the tool might also be used for controlling transmissions with 1,000 gear ratios. And for new transmissions, it significantly speeds up simulation: With model-in-the-loop, it takes around 20 minutes to control any gear speed and perform every power-shift. This way, the functionality can first be developed on the model before testing its implementation in the vehicle later on. IAV is getting the method patented and is already using it in cooperation with customers for hardware evaluation.

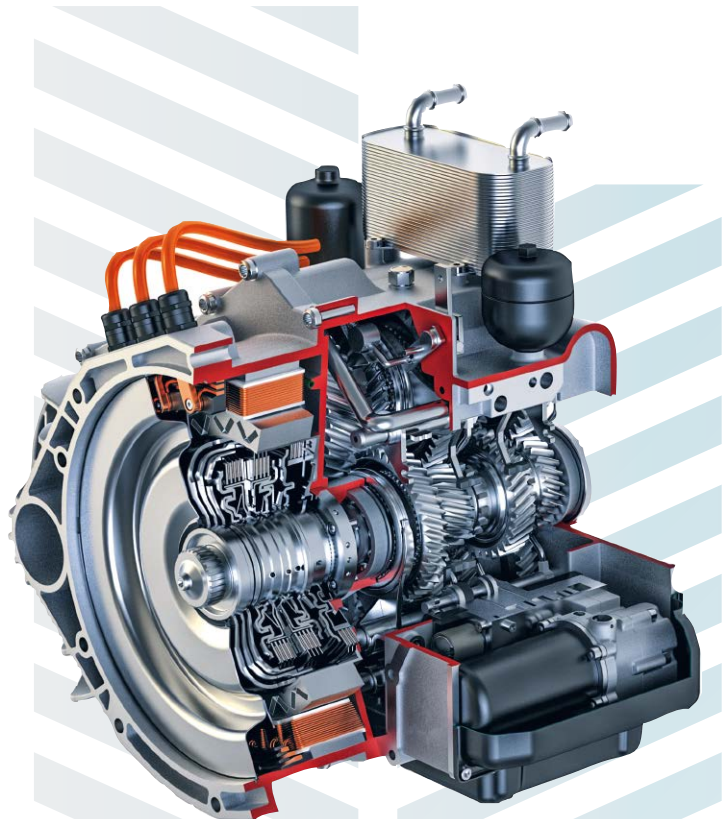

Modern Approach in the Design of Compact Axle Gears

Axle designers face multiple challenges in the design of gear sets: increasing torque density requirements; growing demand for high levels of refinement; and continually improving efficiency targets. The discrepancies between actual manufactured tooth profiles and the geometry predicted by current simulation software, combined with currently under-developed analysis methods, make it increasingly difficult for the engineer to create robust designs, optimised within their package space, without extensive hardware testing and costly development loops.

■ Matt Hole, Design Manager, Drive System Design

■ Ben Wisbey, Gear Specialist, Drive System Design

New analytical approach

The conventional view is that high efficiency, quiet operation and good durability are conflicting aims, but many of the old design rules originated from manufacturing limitations; the trend towards face milled, rather than face hobbled, gears in Europe has opened up new possibilities. In an age when car makers are pushing for smaller, lighter assemblies throughout the vehicle, any supplier bidding with an oversize design that is over focussed on maximum durability is at an immediate disadvantage when tendering for a contract.

Hypoid gears designed by classical industry guidelines do tend to be over designed for durability and have compromised efficiency and non-optimal NVH. Driveline engineering consultancy Drive System Design (DSD) has investigated the potential for using smaller diameters and hypoid offsets, questioning the established design rules for geometry and layout.

To increase the torque density of axle gears, the new process is based on modern fatigue theory and a finite element approach has been developed to predict the life of a hypoid gear pair. This approach also allows multiple iterations of a design to be carried out in a simulation environment, eliminating the cost and time spent procuring and testing physical hardware.

Taking full advantage of such sophisticated modelling requires an in-depth understanding of the manufactured tooth shape to ensure valid results. There are limits to the extent to which software tools can enable designs to be downsized; pushing too far makes the design oversensitive to manufacturing variables such as tolerances, leading to protracted development of the machining processes which can be a particular issue when milling gears.

DSD has established the boundaries for safe application of the new design technique through extensive practical experience of manufacturing, comparing software-predicted geometry with the manufactured form to identify the issues and establish the avoiding actions required. The company has designed five sets of high efficiency, torque-dense gears for RDMs (rear drive modules) and RDUs (rear drive units) in the last year alone.

Traditional hypoid gear design used offsets of between 10 and 20 percent. During the last 20 years this has tended more to the 10 percent value but in order to improve efficiency significantly the target is 5 percent or less in some cases, which would improve axle efficiency by approximately one percent (for example, from 96 to 97 percent). A difficulty emerges in that low offset (whilst reducing the sliding) makes



lapping less efficient as a process as a longer manufacturing time is required.

Lower spiral angles can improve bearing efficiency by reducing axial loads and enabling angular contact bearings to replace taper rollers; the reduced contact ratio can be counteracted by increasing the tooth depth on face milled gears. NVH and durability levels can also be maintained by increasing the face width on milled gears; an approach not possible with face hobbing due to issues with root form from the tooth taper. Face milled gears are not a perfect answer in that they often contain higher mesh frequency harmonics due to the tooth finish from grinding that are difficult to isolate in vehicle (i.e. 1–2kHz). To counteract this a system approach must be taken.

DSD has particular expertise in the correlated modelling of NVH properties of high efficiency gears which allows the accurate prediction of NVH (transmission error and modal response) and efficiency performance during the concept phase of design. This has been particularly advantageous in the design of gearing for electric vehicle transmissions which require: good refinement because of the low cabin noise levels; high efficiency to maximise range; and good durability under the action of very high motor torque loads from low rpm.

Recently DSD undertook an analysis of an improved Tier 1 axle that showed the gear design to be good, but in the context of the OEM axle and suspension to be significantly worse in vehicle. A design solution was identified that was suitable to go to production although considered in the context of the gear transmission error should have been worse. In this case the significant influence was the load vector generated by the gearset and the effect it had on the propagation of the gear excitation (transmission error) through the axle system.

In order to survive or grow in the future Tier 1's must shed their traditional guidelines and push the boundaries of gear design and manufacturing. The key is to move away from a design approach that considers each component in isolation and embrace a system engineering philosophy. Efficiency and weight will be the new drivers and engineers will need to turn to the next generation of materials to meet durability and NVH requirements.

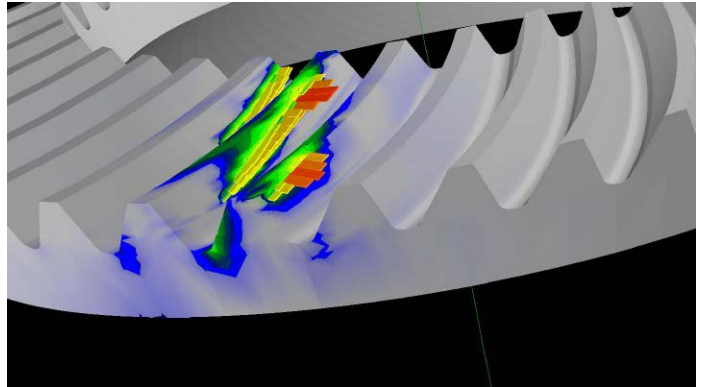

Figure 1 Driveline engineering consultancy Drive System Design (DSD) has investigated the potential for using smaller diameters and hypoid offsets, questioning the established design rules for geometry and layout (image of an Ansol model)



Figure 2 The discrepancies between actual manufactured tooth profiles and the geometry predicted by simulation software make it increasingly difficult for engineers to create robust designs without extensive hardware testing and costly development loops

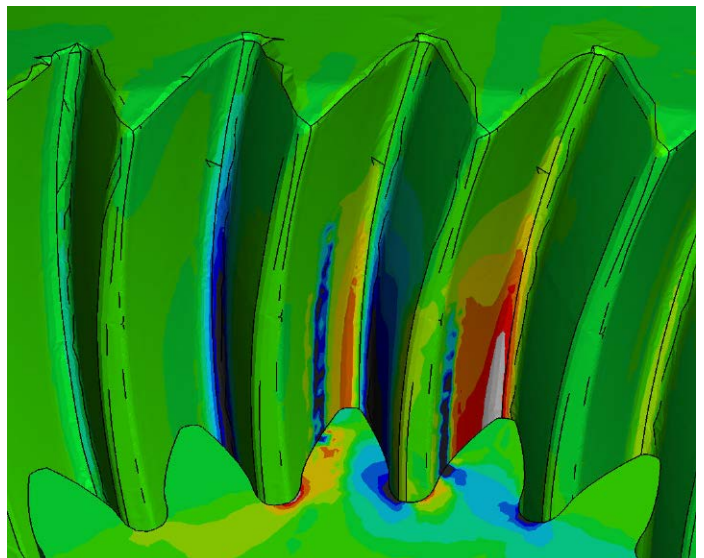

Figure 3 Image is of an abaqus contact model generated from laser scanned gears. The image is a view onto the ring gear with the pinion gear sectioned

Increased performance for hybrid vehicles

eTWINSTER – the First New-Generation Electric Axle System

The GKN-developed eTWINSTER is the first next-generation electrical axle system, providing a step-change in efficiency and dynamic performance of hybrid vehicles.

■ Dipl.-Ing. Jan Haupt, Advanced Engineering Driveline Systems, GKN Driveline International GmbH

■ Co-Autor Dr.-Ing. Dirk Güth, Advanced Engineering Driveline Systems, GKN Driveline International GmbH

A look at the current registrations of hybrid and electric cars clearly shows that these vehicle categories are gaining essentially more importance worldwide. GKN supports this growth with a broad portfolio of electrical transmissions and axles, and advances the development of increasingly powerful and efficient driving units. Now, with the development of the GKN eTWINSTER, another fantastic development stage has been achieved in electric drive systems, significantly improving the drive performance of hybrid vehicles.

Many electric axle systems currently available on the market must be disconnected at high driving speeds because of the maximum permissible rotational speed of the electric motor and the applied gear ratio, whereby even drag torque of up to 2.5 Nm on the axle can re-

main (see Figure 1). The result is a significantly negative influence on the overall efficiency of the drive system, in particular at high speeds.

Due to the increased system weight (caused by battery, electric motor, inverter, etc.) the driving dynamics of a hybrid vehicle are clearly affected in comparison to a corresponding conventionally-powered (all wheel driven) vehicle, which is primarily noticeable by means of reinforced understeering. Ultimately, it is the traction of the vehicle through the use of open differentials that is limited.

The GKN eTWINSTER acts exactly on these weaknesses: one key feature is the integration of the GKN TWINSTER technology, already introduced successfully to the market in AWD rear axle systems (for example, in the drive train of the JLR Evoque).

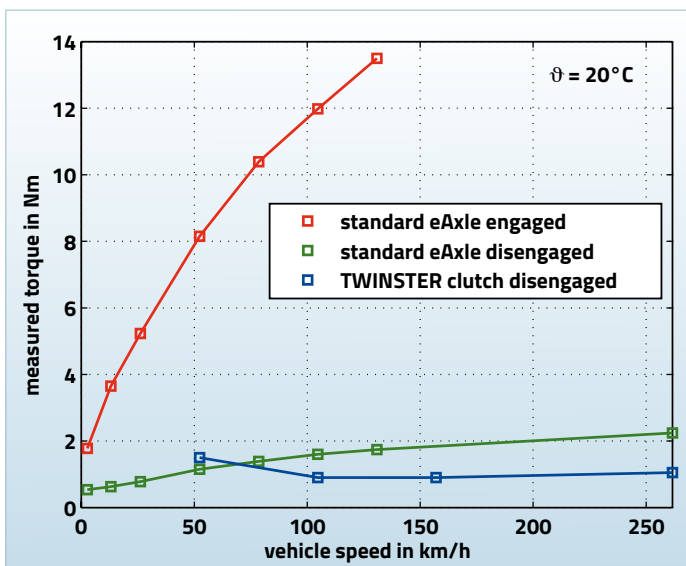

Figure 1 Drag torque disconnection unit comparison

Structure

The electric axle for the Volvo SPA Platform serves as the basis for the system, developed and produced in series since mid-2015 by GKN. Among others, this is built into the new Volvo XC90 T8 Twin Engine Plug-In and is helping the flagship of the Volvo Group to achieve an average fuel consumption of 2.1 litres/100 km and an acceleration of 0 to 100 kph in just 5.9 seconds. Due to the work that took place on the vehicle during series development, GKN very well knows the vehicles and other areas surrounding electronic rear axles. For these reasons, the XC90 was chosen as the experimental vehicle for the development of eTWINSTER.

The electric rear axle is built coaxially, with the hollow motor shaft of the electric motor and the differential being positioned concentrically together (see Figure 2). By means of a countershaft, the output of the electric motor is connected with the final drive. The right rear drive shaft travels centrally through the electric motor. In the current series version, the electric drive axle is disconnected at a speed of 160 kph using a patented electromagnetic actuated disconnect differential.

For the newly developed GKN eTWINSTER, the fundamental architecture of this axis (coaxial layout, arrangement of the countershaft) has been taken over. As a key differentiator, however, the disconnect differential has been replaced by two side-by-side TWINSTER clutches with hydraulically actuated pistons. These could essentially be put in the same installation space as the outgoing design. The requirement was the integration of the final drive into the outer disc carrier and the space-saving positioning of the clutch disks below it.

In order to build up the required system pressure, an actuator, consisting of a BLDC motor, pump and valves, was integrated into the main housing. The transmission and the actuators share a common oil circuit and therefore use the same oil. The oil circuit is at the same time the basis for the applied dry sump of the transmission. The BLDC motor and pump have therefore been arranged in the area under the transmission in the common oil sump. Due to available package space, the hydraulic valves were also integrated in this area.

In total, the GKN eTWINSTER uses three valves. Two valves spread the oil on the right and left clutch pistons, the third valve controls the lubrication of the bearings, gears and cooling of the clutch. This allows not only the clutch pressure, but also the lubricant flow to be regulated on demand. Distribution of the oil on the individual lubrication points is adjusted through different orifices.

The key elements of the GKN TWINSTER clutches, such as the actuator, the clutch disks and the hydraulic pistons, are GKN-standardised system elements with fully defined physical, logical and material interfaces, the so-called "building blocks". This common-part strategy makes it possible to robustly develop and create a complex system such as the GKN eTWINSTER within a short period of time.

Function

The power generated from the electric motor will be delivered from the drive pinion of the electric motor to the gear of the countershaft. From there, the power flows over the shaft pinion to the final drive. By applying pressure on the clutch pistons, an axial force is exerted on the disk packs and the inner disk carrier is connected to the outer disc carrier. The maximum clutch pressure is 35 bar. Depending on the chosen clutch pressure, (in the design shown here) up to 1200 Nm drive torque can be applied to each rear wheel. For other applications the clutch torque is scalable through changing the number of disk plates.

In accordance with the driving situation, both clutches can be completely independently controlled and thus the torque can be distributed freely on the rear axle between the right and left wheel. This distribution is regulated by GKN's own vehicle dynamic controller, the so-called TASC (traction and stability control). Dependent on various input signals, such as wheel speeds and steering wheel angles, the controller calculates the required torques at the rear wheels and transmits these to the hardware controller for the BLDC motor and valves. The flexible structure of the software and the division into hardware and vehicle dynamic controller enables a quick and easy implementation in a variety of applications.

Benefits

Due to the targeted controllable distribution of torque between the rear wheels, the eTWINSTER offers the opportunity of torque vectoring on the electrically driven rear axle. When cornering, the outer wheels will be supplied with more torque than the inside wheels. This comes as part of a dynamic tuning of the vehicle being specifically exploited; in order to reduce understeering of the vehicle by a positive yaw moment.

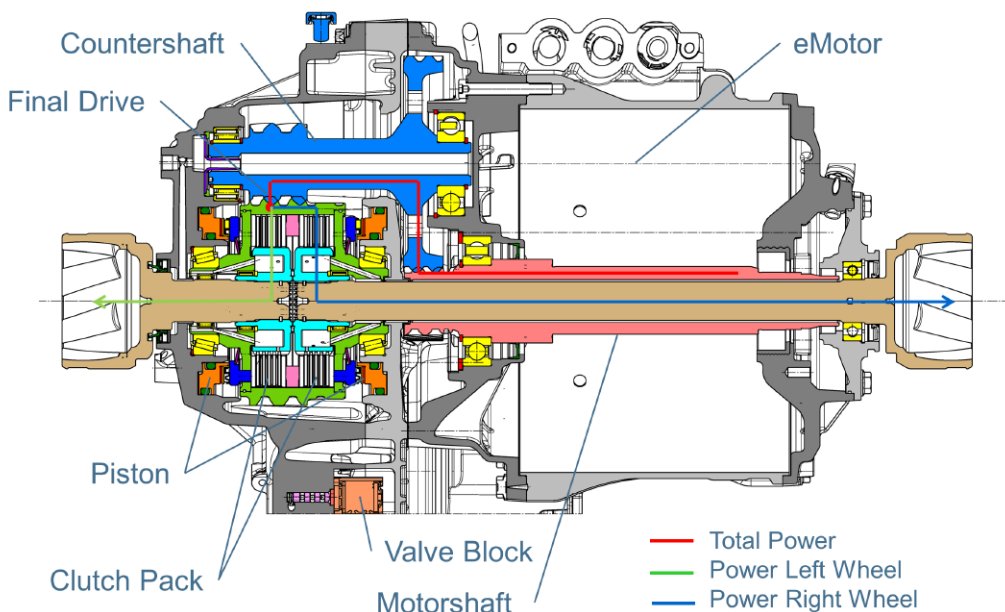

Figure 2 eTWINSTER rear axle module

Furthermore, the vehicle dynamics can be even more positively influenced by a controlled speed difference between the front and rear of the electrically-driven rear axle.

In addition, the eTWINSTER concept has a particular advantage compared to conventional four-wheel drive concepts. Even in deceleration, targeted torques can be lead to the wheels of the rear axle by taking advantage of the regeneration function. This situation is comparable to torque vectoring via brake intervention, during which the inside wheel brakes. Only in the case of the GKN eTWINSTER driving power is not lost in the brakes, but rather won back through regeneration.

Depending on the tuning of the vehicle, with the measures described, a neutral or even oversteering behaviour of the vehicle can be achieved. The vehicle becomes entirely more agile, the result is reflected in a smaller cornering radius and an increased lateral acceleration.

The GKN eTWINSTER as further function offers the opportunity to lock the rear axle. Comparable to a limited slip differential, the two rear wheels can be connected together by synchronous actuation of the clutches. This leads to significantly improved traction and can be used as yaw damping in the upper speed range.

The efficiency of the GKN eTWINSTER is better as well as in coupled state and disconnected state than the conventional electric rear axle. The input of the dry sump and the associated reduction in the splashing loss will improve efficiency in operation. In disconnected state the remaining drag torque of the eTWINSTER is significantly lower than the drag torque of the conventional axle (equipped with differential and disconnect device). This was achieved through targeted measures towards fast and effective de-lubrication of the clutch packs (see Figure 1).

Summary

The integration of the TWINSTER technology in electric drive axles provides a step-change for electric drive train systems in terms of efficiency and vehicle dynamics whilst setting new standards.

With its torque vectoring and LSD function, the eTWINSTER creates more agile and safer hybrid and electric vehicles and ensures, through the use of the TWINSTER clutches in combination with further optimisation measures, such as the dry sump, a significant increase in efficiency of the entire system.

When you have zero tolerance
for anything short of perfect...

A.J. Rose is the Perfect Partner

As a premier supplier to the automotive industry, A.J. Rose is well known for perfection in medium- to high-volume production of precision-engineered stampings and flow-formed parts. Our dedication is to product and process integrity. Our focus is on our customers' success.

For more information on A.J. Rose, our capabilities and how we can support your success, visit us at www.ajrose.com or call us at 440-934-7700.



A.J. ROSE MANUFACTURING CO.
Established 1922

MOVING METALS IN INNOVATIVE WAYS

A.J. Rose Manufacturing Company
38000 Chester Road, Avon, Ohio 44011
Phone: 440-934-7700 | Fax: 440-934-2806 | Web: www.ajrose.com
© Copyright 2016 A.J. Rose Manufacturing Company

Supplier of Sensors and Semiconductor Electronics for Transmission Applications

In this article, IHS examines the supply chain for semiconductor ICs, sensors and transmission control units (TCUs) in the passenger car market and provides an analysis of the top 10 transmission control unit suppliers.

- Ahad Buksh, Analyst Automotive Semiconductors, IHS
- Dr Richard Dixon, Principal Analyst MEMS & Sensors, IHS

Market overview

The different transmission systems are made up of manual, automatic, double clutch and continuous variable transmission and AMT, electric variable transmission and dedicated hybrid transmissions (a category defined recently). A key component of automatic transmissions is the control electronics, i.e. a combination of semiconductor ICs and sensing chips that determine and process information and send signals to the actuators of the system.

IHS is tracking the market for these components and forecasts that the value of semiconductor ICs and sensors will exceed \$1.7 billion in 2021, up from \$1.45 billion in 2015 – a CAGR of 3.1 % over this period. Shipments of such devices amount to a CAGR of around 4 % over the same period.

Sensors are the eyes and ears

Sensors play a key role in transmissions (see IHS article in CTI Mag, May 2015). The overall market for the major sensing devices is shown in the graphic below (Source Automotive Semiconductor Intelligence Service).

The categories of measurement comprise pressure, speed, temperature and position. Pressure sensors and position sensors are the fastest growing categories; both exhibit a CAGR of 5 % in value from 2014 to 2021.

Pressure and positions sensors are used more prevalently with CVTs and DCT transmissions. VW's 7-speed Direct Shift Gearbox has 2 pressure sensors and 4 position sensors. Meanwhile JATCO's newest transmission features 5 pressure sensors and 3 position sensors.

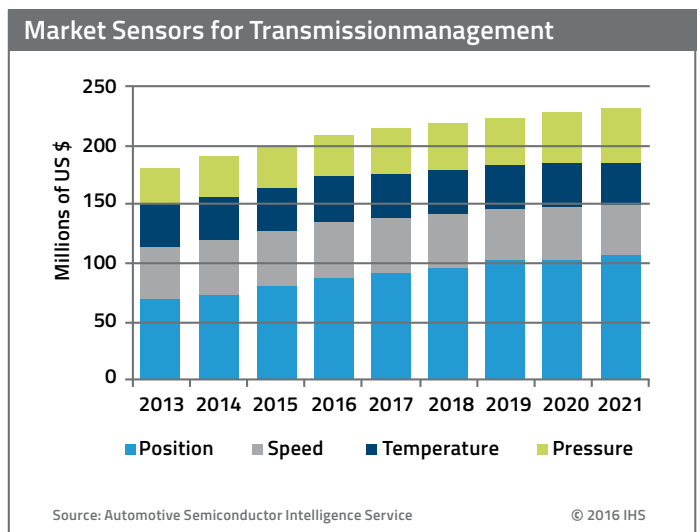

Figure 2 Worldwide market forecast for sensing in transmissions (IHS)

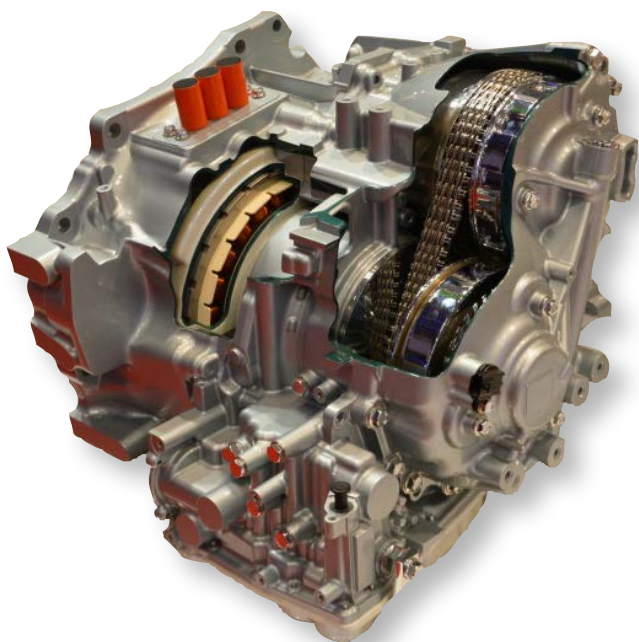

Figure 1 Caption: CVT transmission can feature as many as 5 pressure sensors (Courtesy JATCO)

Speed and temperature sensors are standard devices that do not change significantly for automatic transmissions in the forecast period. Usually speed is found on the input and output shafts, and one temperature sensor is typical for any automated transmission independent of type. Manual transmissions have no sensors except for those cars with stop-start systems, which use position for neutral gear position detection.

Supply chain for sensors

A number of sensing technologies are in play for transmissions and other powertrain applications, including notably Hall sensor ICs. This device consists of the element (or die) with a Wheatstone bridge structure, produced in silicon CMOS. The sensor IC or sensor switch IC is the bridge structure plus an ASIC monolithically integrated.

Hall is very widely deployed and has been accepted because of ease of integration, self-test functionality and operation in rated temperatures of 125 °C+ for under-the-hood environments. AMR also works well in these environments. Suppliers of Hall devices include Allegro Microsystems, Micronas, Infineon, Melexis, and ams.

A variant on the Hall Effect IC includes 2- and 3-D Hall ICs. In standard Hall sensors, the sensitivity direction is usually perpendicular to the chip, while in AMR it is parallel to the chip. Melexis is the major proponent of this 3D approach having shipped many tens of millions of its "Tri-axis" sensors per year for powertrain applications.

In the case of Melexis, the chip has an integrated magnetic concentrator to allow 3 (though more often 2) axes of B-field measurement compared, which extends the spatial resolution performance in the

lateral dimensions. Companies like Micronas, ams, Infineon and Allegro have been quick to follow with their own 2-D Hall IC developments.

Another key technology is the anisotropic magneto-resistive (AMR) effect. NXP is a major proponent of this kind of device. Such sensors suit position sensing at high temperatures.

Potentiometers and other inductive type technologies (e.g. Permanent magnetic Linear Contactless Displacement Sensors, patented by TE Connectivity) are also in use. However, Hall represents the dominant measurement principle today.

Allegro Microsystems and Infineon dominate for speed sensors used on the input and output shafts. TDK is one of the main suppliers for temperature ICs.

Sensata, Bosch and Denso provide pressure sensors typically operating in the range of 20–70 bar. Sensata's technology is based on the ceramic capacitive pressure principal or alternatively micro-fused strain gages on metal (for very higher pressures). The company sells a large number of sensors for powertrain applications, especially transmissions. Bosch and Denso are also supplying gear boxes with MEMS micromachined type devices (again on metal substrates due to the harsh pressures).

Note that typical integrators (the sensor module makers) of position sensors include EFI Automotive, TE Connectivity and Bourns. Continental buys pressure sensors for integration from companies like Sensata, for instance.

Transmission control unit supply chain

Transmission control units or TCUs represent the brain of the automated gear box, taking sensing inputs, making decisions and giving "orders" to the actuators.

Among the suppliers of these control units, Continental has been the front runner in supplying TCUs for the last couple of years. Its strong relationships with German and North American OEMs helped the company retain 23% share of the market in 2015. Continental provides mainly automatic and DCT designs – the most prevalent transmission design in North America and Europe respectively.



Bosch is the second biggest TCU supplier. Its strength is supplying automatic TCUs for a number of OEMs including but not limited to Ford, GM, BMW, and Volkswagen. Bosch's TCU revenue had a high single digit growth in 2015.

The third biggest TCU supplier is Denso. The primary transmission designs supplied are automatic, CVT and EVT for hybrid vehicles. Denso

is the biggest supplier in Japan, with more than 85 % of its TCUs found in Toyota vehicles.

The remaining suppliers have a diverse customer base with different OEMs around the world. Keihin and Fujitsu Ten are two exceptions – these companies each solely support one particular OEM.

The TCU market is a consolidated market and there is not much room for new players. Today, the combined market shares of the top 10 suppliers amount to more than 97 % of the global market.

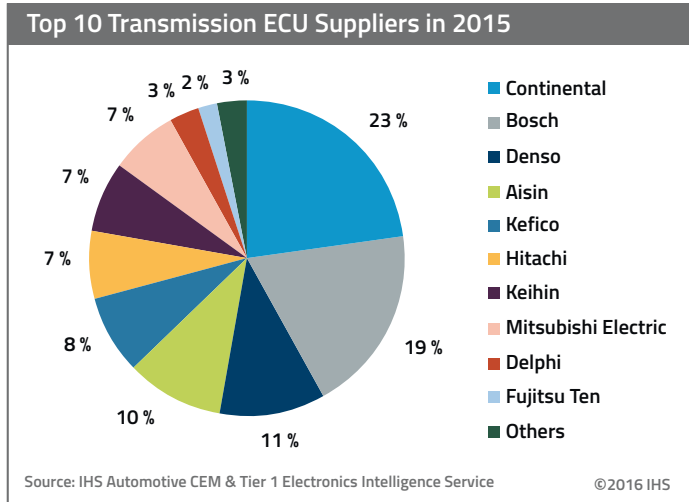

Figure 3 The top 10 Transmission Control Unit Suppliers serve more than 97 % of the TCU Market

Conclusion

The transmission business is a staple of demand for electronic, semiconductor and system suppliers in the next 6–7 years. The industry supports 10s of component companies.

Notes

Data in this article come from the following IHS datasets and reports: Automotive Semiconductor Intelligence Service Automotive OEM & Tier 1 Electronics Intelligence Service Automotive Sensor Intelligence Service H2 2015

For more information please contact

Ahad Buksh, Analyst Automotive Semiconductors, IHS, ahad.buksh@ihs.com
Dr. Richard Dixon, Principal Analyst MEMS & Sensors, IHS, richard.dixon@ihs.com



In our plants and in our products, we're all about better performance.

At BorgWarner, we never stop improving. It's a goal we set for our production capabilities as well as our market-leading products. We're making significant investments in our award-winning manufacturing facilities to bring the next generation of innovative transmission technologies to the automotive marketplace. Our investment in state of the art manufacturing processes is safely and efficiently delivering world-class quality products to our customers around the globe. At BorgWarner it's what product leadership is all about.

Follow-up report on the 14th International CTI Symposium –
Automotive Transmissions, HEV and EV Drives, 7–10 December 2015,
Berlin, Germany

The Next Generation of Hybrid Transmissions

At previous CTI Symposia, it became increasingly clear that hybrid transmissions call for an integrated view of powertrains. As a logical consequence, DHTs (Dedicated Hybrid Transmissions) were defined and discussed in public for the first time in Berlin. DHTs are a new breed of hybrid transmissions, and more than just an add-on solution. Two other forward-looking topics were also in the spotlight in Berlin: the impact of autonomous driving on transmission and drive technology, and the question of what energy forms tomorrow's mobility needs. There is still ample scope for development – not just for electric cars, but for fossil and regeneratively produced fuels too.

■ Gernot Goppelt

The central importance of automotive transmissions was reflected in the 16 Topic Sessions on offer for the 1300 visitors to the CTI Symposium in Berlin. At the start of Day One, Professor Ferit Küçükay summed up the conflicting priorities for today's transmission and drive developers, noting that there is still plenty of room for improving the conversion efficiency of chemical energy, for instance in conventional fuels or battery technology. He pointed out the new opportunities that arise from processing driver, vehicle and vehicle environment data, for example when optimizing operation strategies. After all, powertrains are increasingly affected by automated systems that improve drive comfort, driving safety and efficiency.



Yes to electrification – as long as it is affordable

The first plenary speaker, Dr Eckhard Scholz, CEO Volkswagen Commercial Vehicles, reminded listeners that drive electrification will need to make sense financially, particularly for customers in the commercial sector. Whereas emotional aspects can play a role when choosing passenger car, SME fleet operators have to

calculate the costs for the entire lifecycle on a strictly rational basis. Put simply, "How much will a kilometre cost me?" Lower costs for energy and maintenance spoke in favour of electric vehicles, while their significantly higher purchase price and lower residual value were disadvantages. Dr Scholz thinks electrified drives will gain ground mainly in the urban transport sector, especially with CO₂ emission ceilings getting lower all the time. However, he believes financial subsidies are needed to prompt commercial users to go electric.

Downsizing hybrid transmissions

Mihir Kotecha, CEO Getrag Corporate Group, focussed on powertrain scaling in his lecture, right up to today's and tomorrow's hybrid drives. He began by presenting current Getrag hybrid transmissions. Since the electric motor is coupled to one partial transmission within the DCT, they can be scaled from around 15 to 75 kW without affecting package. Kotecha then surprised listeners with an interesting mental exercise: he listed the qualities of various powertrains, then concluded that while they were improving all the time, they were still not universal enough in terms of usability and fuel efficiency. He ran through different examples of drive technology, from 1975 through 2015 to the upcoming scalable mild hybrids and plug-in hybrids. Looking ahead, he posed a provocative question: What if we set a maximum speed limit of 160 km/h? If so, almost every hybrid drive component could be made significantly smaller and more efficient. As an example, Kotecha

said a 100 kW electric motor and 50 kW internal combustion engine would need just two or four gears respectively. The resulting drive would be equally suitable for all-electric, emissions-free urban driving and for longer hauls. Thanks to the highly dynamic nature of the electric motor, it could be used far more universally than previous drives.



Dedicated hybrid drives – a new drive category

Dr Robert Fischer, Executive Vice President Engineering and Technology Powertrain Systems AVL, introduced the new category of Dedicated Hybrid Transmissions (DHTs), which was given its own separate session at the CTI Symposium 2015. Unlike add-on solutions, he explained, DHTs are “hybrid transmissions where the electric motor performs functional transmission tasks” and is thus non-optional. He cited the powersplit Toyota hybrid as a classic example of drive aggregates grouped around a planetary gearset. Robert Fischer also mentioned the GM Voltec and solutions from Renault, GKN and Professor Tenberge, Ruhr-University Bochum. These were presented later

on in the dedicated DHT session, along with AVL's approach. Fischer went on to say that while the dedicated approach is less compatible with conventional drives, it also means individual components can be specified more efficiently. At production volumes of 100,000 units or possibly even lower, Fischer thinks DHTs could break even and would then become cheaper than add-on solutions.



Dedicated hybrid drives need production volume

Gerald Killmann, Vice President R&D Toyota Motor Europe, explained how Toyota's successful hybrid concept came about and evolved. He said not everyone knew that in the past, Toyota used other architectures besides the PSD hybrid. His examples included a serial hybrid drive for a city bus (Coaster) in 1997, and a parallel hybrid with electrified rear axle in a van (Estima) in 2001. In 2003, there was even a parallel diesel hybrid in a small truck.

To date, Toyota has sold around eight million hybrid drives, of which 99 percent meet the definition for DHTs as powersplit hybrids with their planetary gearsets. This scale effect, Killmann says, is one of the critical success factors. Interestingly, alongside the powersplit device full hybrid, Toyota is now more in favour of fuel cells than of further plug-in hybrid development. Kill-



mann says this is because of hydrogen's very high energy density, which he sees as a big advantage over batteries for long distance driving.

Customer data for the 2nd generation Voltec

The third plenary speaker on the topic of DHTs was Larry Nitz, Executive Director Transmission and Electrification, GM, who presented the second-generation Voltec hybrid drive. During development, Nitz says, customer data transmitted automatically with vehicle owners' consent played an important role. The data supplier was GM's own in-car Onstar Communication System. The data yielded surprising insights, including the fact that people like to drive their Voltecs dynamically. Nitz puts this down to the drive's 'liquid acceleration', and to the fact that drivers could have fun driving with a clear conscience, since their vehicles emit no local emissions. He said differences between the new Voltec drive and its predecessor include electric motors with greater power density, and a higher all-electric range of 53 miles. One fundamental change was that there are now two planetary gearsets, not one. That permits more operating modes, including most efficient electric driving with one or two electric motors, and two eCVT modes that complement a serial mode.



Climate change calls for radical technological change

It is very hard to predict which drives will prevail in future in detail, as Wolfgang Müller-Pietralla, Head of Corporate Foresight at Volkswagen, demonstrated on Day Two of the symposium. He pointed out that the global climate will reach a 'tipping line' if we do not progress quickly enough towards energy forms that are low in CO₂ or CO₂-neutral. By 2030, he expects half of all vehicles to be at least partially electrified, a forecast he concedes is volatile. He also believes inductive charging systems could boost the electric car sector, and that power-to-gas might be a way to produce methane CO₂ neutrally, making natural gas

hybrids an interesting proposition. Müller-Pietralla says our relationship to cars will change significantly. “Everything will be connected, predictive systems will become more important, and there will be convergence with non-automobile industries”. He does not believe companies like Google want to develop and make automobiles themselves, saying their interest lies more in “the time customers spend in their cars”.



A plea for electrofuels

Dr Rolf Leonhard, Chairman of the Advisory Board, Bosch Engineering GmbH, began by spelling out that global energy consumption makes a global warming cap of 2 °C untenable. He said China, for instance, would exceed the planned CO₂ emissions figure by around 400 percent, and that there was a gap between vision and reality in the EU too. By 2040, the increase in traffic would, sadly, 'overcompensate' for reductions in CO₂ emissions. Leonhard says electrofuels produced with regenerative energy are an even more likely solution than all-electric mobility, particularly since long-distance traffic will grow disproportionately. Leonhard thinks the EU can reduce CO₂ emissions by 85 percent in 50 years if we cut fuel consumption by 60 percent, and use battery electric, plug-in hybrid and electrofuels in equal measures. If electrofuels are produced using power-to-liquid, 'CO₂ recycling' would be possible providing the hydrogen used for synthesis was produced regeneratively.



to 3, but fully automatic transmissions are required from Level 4 upwards. Which transmissions prevail will also depend on how much comfort drivers expect. Devauchelle thinks step transmissions such as DCTs will be better for active driving functionality on Levels 3 or 4, with stepless transmissions for cocoon driving on Level 5. However, he continued, the more powerful electric motors become, the more their superiority in launch and boosting would compensate for their lower comfort. Devauchelle says Level 3 and 4 autonomous driving can be achieved with a 48-volt on-board system, while Level 5 requires full hybridisation with ≥ 300 volts. Looking ahead, he foresees a 'Transmission 2.0' that will combine the characteristics of different transmission types.

Mid term outlook

Michael Schöffmann, Head Transmission Development Audi, spanned an arc between future demands and the company's current hybrid technology. He thinks it is crucial for all levels of electrification to preserve total cost of ownership, and predicts that by 2025, energy density will have risen from roughly 220 to around 800 Wh/l. That would significantly improve the ranges possible with acceptable battery sizes.



His talk centred on the new seven-step Audi S Tronic DCT. This has a modular build, with options that include all-wheel and hybrid, and extend up to a plug-in hybrid with a 100 kW electric motor. Looking ahead, Schöffmann also sees the possibility of a two-ratio electric rear axle for internal combustion powertrains. This would simplify transmissions by reducing the number of ratios inside to around four.



How autonomous driving impacts on vehicle technology

Dr Peter Rieth, Systems & Technology head at Continental's Chassis & Safety division until the end of 2014, addressed the outlook for autonomous driving. Functionally, he defined three phases – 'sense', 'plan' and 'act'. Put simply, these equate with sensors, control units and actuators in automobiles. Dr Rieth

said that with automation, driver and passenger workloads change as they delegate more and more responsibility. In line with SAE J3016, he distinguished six progressive levels of automation (0 to 5), whereby Level 5 means full automation without driver input. Dr Rieth believes a very high degree of automation can be achieved by 2020, with fully automatic driving without driver input by 2025 at the earliest. In both cases, all automobile systems, right down to drives, would need to be redundant because naturally, autonomous driving is only possible if accidents and failures of all types are ruled out 100 percent.

Autonomous driving changes the DNS of transmissions

Guillaume Devauchelle, Vice President Innovation & Scientific Development, Valeo, explained the impacts of autonomous driving on transmissions. He too referred to the SAE J3016 definition. Accordingly, clutch-by-wire solutions plus two or three pedals are also possible for Levels 1



Tetsuya Takahashi, Senior Vice President R&D, Jatco, focussed on drivers' needs and how modern CVTs can help meet them. On one side stand rational requirements such as consumption, comfort and safety; on the other, emotional aspects such as a responsive, sporty driving experience. Takahashi says the latter will no longer play a role in tomorrow's autonomous driving,

but that today's transmissions must cover both aspects. He described the stepped D-Step mode in Jatco CVTs, designed for dynamic driving, as a functional complement that can do both. The new Jatco CVT7 improves efficiency by 5 percent, and has an interesting 8.7 spread made possible by a secondary gearset and a new thrust belt. Takahashi added that the Jatco CVT8 Hybrid benefits from the use of a dry multi-plate clutch.



Drive train 2030 – podium discussion

The overarching questions at this year's podium discussion were "What will powertrains look in 2030 – and will electric cars stay in a niche?" Participants were Dr Wolfgang Ziebart, Michael Schöffmann, Prof. Friedrich Stockmar, Jörg Grotendorst, Prof. Peter Gutzmer, Prof. Friedrich Indra and presenters Ulrich Walter and Rolf Najork. As in previous years, the public were able to vote on multiple questions.

On the question of the future of electric drives, the great majority believed internal combustion engines would still be around for a long time, and that electrification would progress slowly. However, there was broad agreement that 48 V hybrids will quickly prevail. As Friedrich Indra noted, one reason is that unlike more highly electrified drives, they have an acceptable cost-benefit ratio. How will the range of electric automobiles develop? An astonishing number of visitors can imagine vehicle ranges of 1000 kilometres by as early as 2025 or 2030. While that is certainly feasible, Dr Ziebart questioned whether it made sense, since charging times would increase accordingly. Prof Gutzmer predicts lithium-air batteries by 2030, but likewise see little sense in such high ranges. For Jörg Grotendorst, the main thing is to create an infrastructure where people can recharge everywhere, making range issues less important.

How much electrification makes sense in the near future? Interestingly, most listeners and discussion participants backed mild and plug-in hybrids, not full hybrids. Michael Schöffmann sees mild hybrids as a standard solution, with plug-in hybrids for heavy vehicles to meet legal requirements. Looking ahead to 2030, most of the audience voted for DHTs (Dedicated Hybrid Drives) as a sensible form of electrified drive. Prof. Stockmar favours electrified DCTs due to their efficiency; Michael Schöffmann sees interesting competition between DCTs and DHTs, while Dr Ziebart and Prof. Gutzmer expect a considerable percentage of manual shift transmissions to remain. Gutzmer says e-clutches could then become more important, for example by enabling sailing functionality. However, will powertrains still be an important criterion at all for tomorrow's drivers? Three in four listeners

said 'yes', though the podium was more sceptical. Prof. Stockmar sees a general drop in people's desire to own automobiles, while Wolfgang Ziebart believes the average customer does not notice any difference. Finally, everyone agreed that we need to look closely at how tomorrow's drivers will use technology. "For older drivers, it will be about more safety," said Professor Gutzmer. "For younger drivers, it will be more about connectivity". He said powertrains would need to deliver accordingly.

Co-existence of drive concepts

As the 14th International CTI Symposium in Berlin made clear once again, automobile drives need to be electrified due to legal requirements driven by real-life CO₂ issues. However, the challenges of low energy density in batteries, lack of infrastructure and high costs persist. The new DHT transmission category offers an interesting opportunity in this respect, since DHTs can be configured for particularly high efficiency in both all-electric and fuel-based modes. DHTs might even be more than just a transitional technology. The question of which transmission topology to prefer is a matter for further discussion, as is the choice of the right energy source. If obtained regeneratively, fuels like methane and hydrogen – and CO₂-neutral substitute fuels for petrol and diesel – still have big advantages due to their high energy density and storage capacity. The question is not necessarily whether electric drives will replace conventional drives, but rather how to get regenerative energy into vehicles.

More information and images: www.transmission-symposium.com

IMPORTANT DATES:

5th International CTI Symposium China, Shanghai, 21–23 September 2016

15th International CTI Symposium, Berlin, 5–8 December 2016



Management News



Rolf Najork (53) has taken over the position of Chairmanship of the Executive Board and the responsibility for development at Bosch Rexroth AG at the begin of February this year. He follows Dr. Karl Tragl (53) who simultaneously left

the company and followed a new direction. Before moving to Bosch Rexroth Rolf Najork was Managing Director of Heraeus Holding GmbH with responsibility for production, purchasing, and development. He held various technical management positions at Ford and Getrag after completing his mechanical engineering studies at RWTH Aachen. As an executive management member Automotive he was then responsible for the division Emobility, Mechatronics, and R&D transmission within the Schaeffler Group.

Bosch Rexroth offers hydraulics, electric drives and controls, gear technology, and linear motion and assembly technology for machines and systems for Mobile Applications, Machinery Applications and Engineering, and Factory Automation.



Ernie DeVincent has taken over the position as Vice President, Engineering, Quality and Product Strategy of Meritor, Inc., effective February 1. In this role, DeVincent has direct responsibility for Meritor's global research and develop-

ment activities, advanced product engineering, quality and product strategy development. Meritor is a global supplier of drivetrain, mobility, braking and aftermarket solutions for commercial vehicle and industrial markets.

DeVincent was most recently Vice President, Transmission Product Development, and Director, Global Platform, at Getrag, a supplier of transmission systems for passenger cars and light commercial vehicles. His responsibilities for product line oversight included the engineering, profitability, quality and delivery of Getrag's high-volume, dual-clutch transmission. DeVincent was also responsible for product line technical development and manufacturing integration in Europe and Asia. Prior to Getrag, DeVincent held various management and engineering positions at Ford Motor Co. for more than 20 years



The Supervisory Board of Schaeffler AG appointed **Matthias Zink** (46), Global Head of the business division 'Transmissions Systems', as a member of the Executive Board of Schaeffler AG as of January 1, 2017.

Matthias Zink will succeed Norbert Indlekofer (58), whose contract was not extended at his own request. Norbert Indlekofer will leave the company on December 31, 2016 and will continue to perform his role as Co-CEO of the Automotive division until that time.

The Schaeffler Group is a global supplier of high-precision components and systems in engine, transmission, and chassis applications as well as rolling and plain bearing solutions for a large number of industrial applications.



Dr Omar Hadded has taken over the position of Director Business Development at the engineering consultancy company Drive System Design Ltd (DSD) from begin of March this year. Before this he acted as consultant on

business strategy and business development in automotive engineering and non-Executive Director Libralato Ltd, an innovation specialist in low carbon vehicle technologies.

From June 2006 to July 2015 Hadded acted as Vice President of TATA Motors European Technical Centre plc.



In January this year **Jeff Lewis** has taken over the position as Vice President of the Transmission & Driveline Business Unit at Ricardo US, a global engineering and environmental consultancy. Before this Lewis worked for AVL as Di-

rector Business Development for passenger car transmissions East Asia at AVL's Shanghai branch and Affiliate Business Manager at AVL North America in the area of simulation and calibration.



Trust ebm-papst Automotive.

Innovative drive and ventilation solutions
for passenger cars and commercial vehicles.

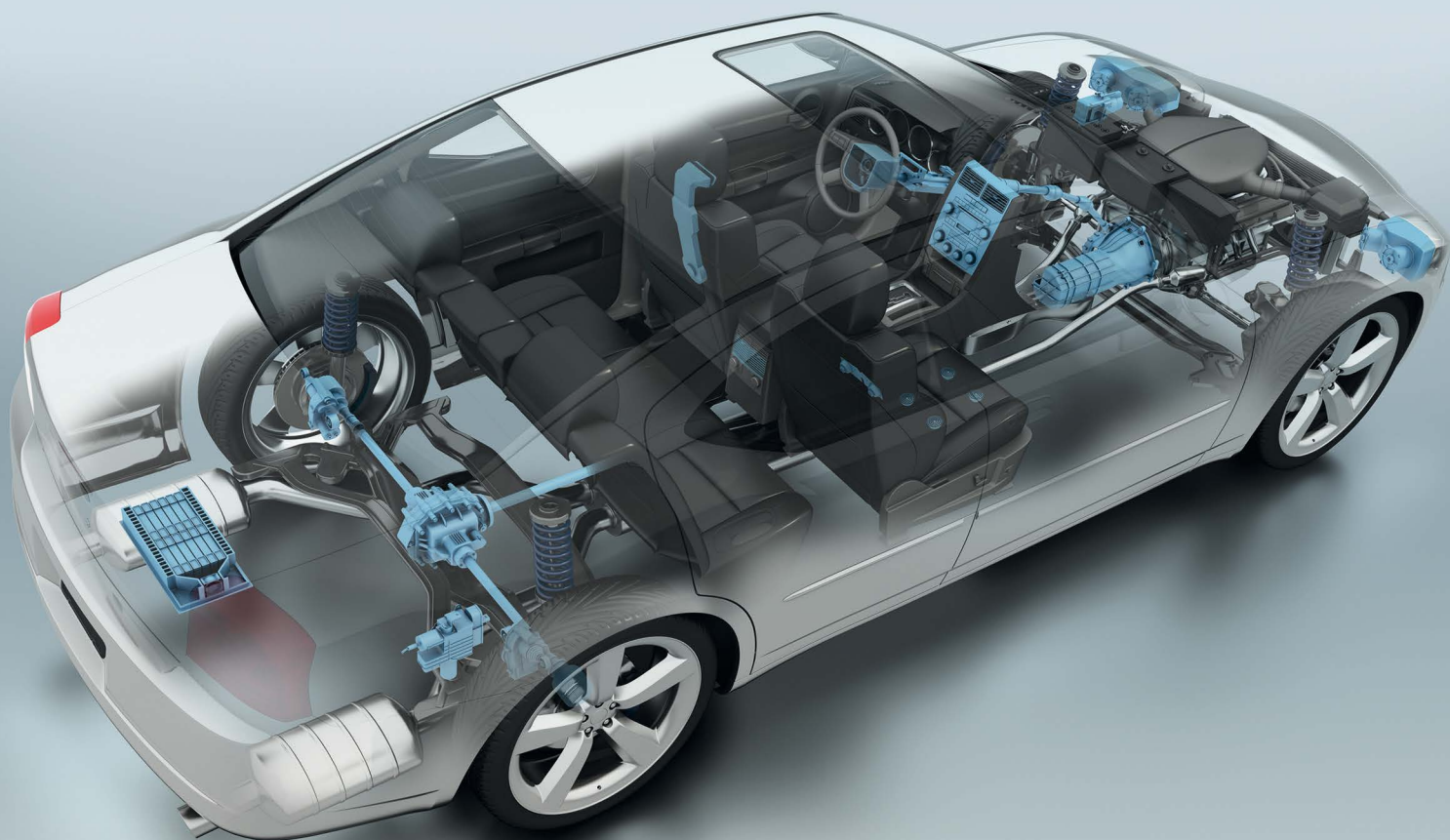

Our fans and drives for the automotive industry offer maximum performance in the minimum space.

- Comprehensive range from seating climate to DNOX pump
- Extremely efficient and reliable system solutions
- Lower weight thanks to the compact design
- Engineering partner with many years' experience of the industry

Further information for your application:

www.ebmpapst-automotive.us | Phone: +1 313 406-8080

ebmpapst

The engineer's choice

WICKERT

hydraulic presses

FIXTURE HARDENING

Your design drives our system!



Precision controlled, yet flexible, Heat Treat and Forming systems, providing profit and throughput, while minimizing finishing operations.

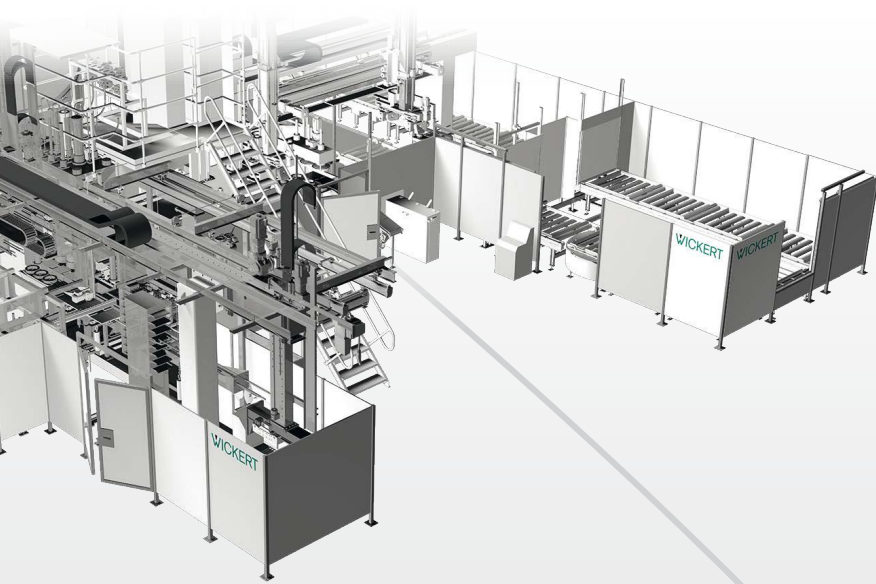

*Single control quality monitoring,
Grip Smart System for hot work pieces,
Auto part / tool change,
Energy efficient mixed part production.*

BRAKES AND CLUTCHES

Custom Systems - 
Linings, Facings, Friction materials.

*Precision filling weight / volume-height,
Insert or over mold, hot / cold, ID Bonding,
Resin Transfer Molding (RTM),
Quick tool change in modular systems.*



Wickert USA
2195 Arbor Tech Drive
Hebron, KY 41048
859 525 6610 x157
sales@wickert-usa.com

www.wickert-usa.com

MEETING THE DEMANDS FOR CUSTOM DRIVETRAIN COMPONENT MANUFACTURING