

DAUCH

**No-Compromise Propulsion  
for the Heavy-Duty Electric Truck**

BORGWARNER

**Optimization of Next Generation  
Integrated Drive Modules**

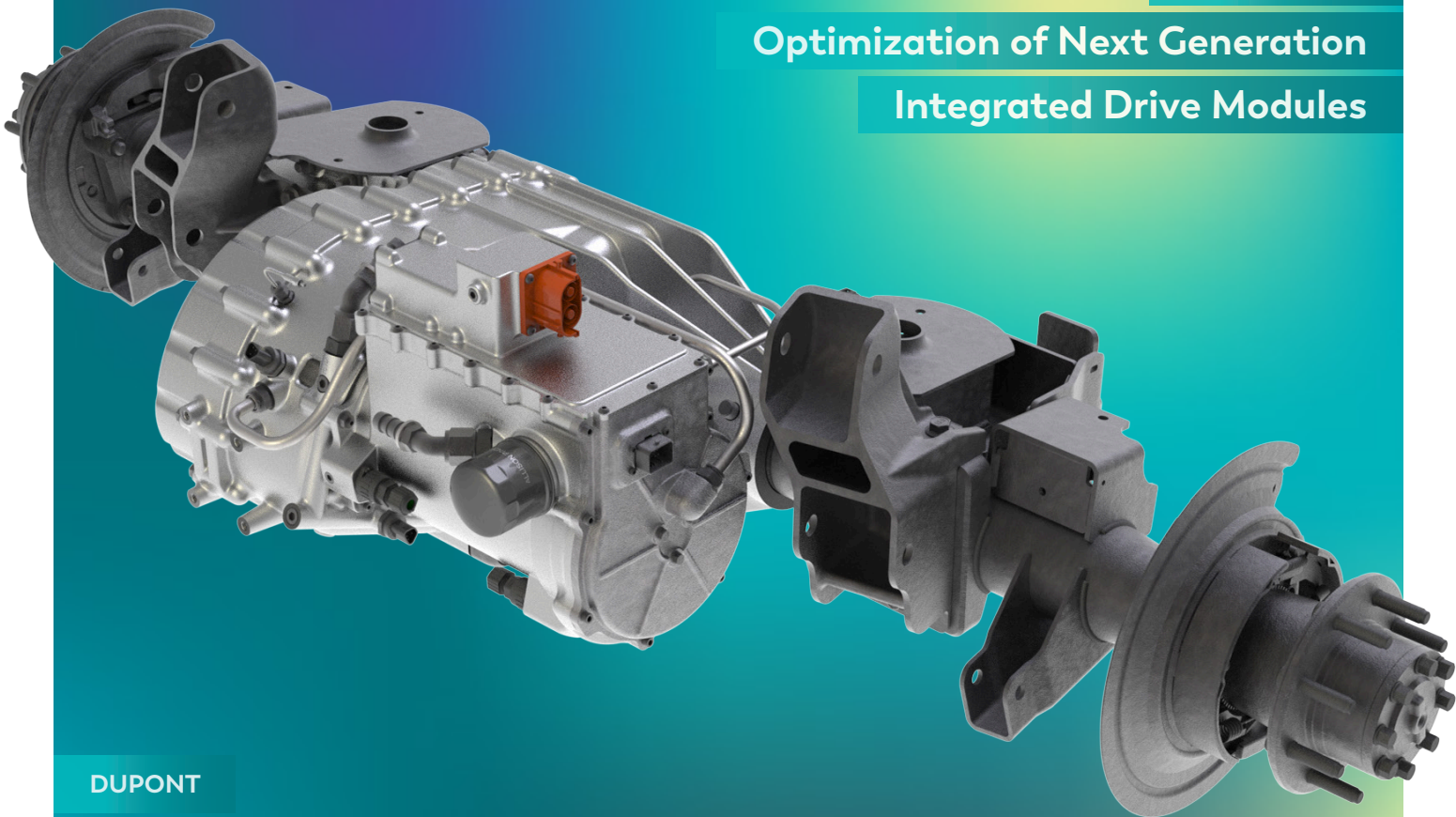

DUPONT

**Effective Solutions for Bearing Insulation  
to Prevent Electrical Erosion**

# Contents

---

- 3 **No-Compromise Propulsion for the Heavy-Duty Electric Pickup**  
Dan Ouwenga, Director – Product Management, Dauch
- 5 **Innovation Powered by High-Fidelity Multiphysics Modeling**  
Dr. Arnaud Leblay, System Engineer Technologies & Innovation, Dr. Pascal David, Engineering Manager Technologies & Innovation, Eric Bourniche, Engineering Supervisor Technologies & Innovation, Adrien Bossi, System Engineer Technologies & Innovation and Harsha Nanjundaswamy, Engineering Director Technologies & Innovation, all BorgWarner PDS
- 11 **Effective Solutions for Bearing Insulation to Prevent Electrical Erosion**  
Philippe Pauchard, Application Engineer at DuPont (Switzerland) and Christoph Berger, Application Development Manager, DuPont (Germany)
- 14 **Faster to SOP: Virtually and with Smarter Testing**  
Dr. Reik Laubenstein, Engineer, IAV Automotive Engineering Inc. and Dr. Johannes Werfel, Team Manager, IAV GmbH
- 16 **JJE Integrated Active NVH Cancellation Range Extender Technology**  
Dr. Cao Yang, Engineering Executive, Company: JJE Technologies Co.,Ltd.
- 20 **Where Mobility Innovation Meets Industry Access**  
Alan Amici, GAMIC Leadership Team
- 21 **High Performance, Magnet-Free Electric Motors**  
Rory Brogan, Founder & CEO, Torev Motors
- 22 **Rethinking Power Conversion for Mobility**  
Kim App, VP Sales & Marketing, Marel Power
- 23 **Interview: “Our Future Hybrids are Designed to Fit in All Current BEV Platforms”**  
Ingo Scholten, CTO, Horse Powertrain
- 26 **Thermal Analysis of Axial-Flux In-Wheel Motors**  
Johannes Becker, Dive CAE and Liam Pek, Dive CAE
- 28 **We Need to Talk About the Grounding Ring**  
Goeff Lewis, Technical Director, Duvelco
- 31 **How AI Redefines Automotive Engineering Workflows**  
Théophile Allard, CTO and co-founder at Neural Concept
- 33 **Start-Ups at CTI SYMPOSIUM USA 2026**
- 37 **Review: AI Fuels Vehicle and Powertrain Development**  
Gernot Goppelt, CTI Correspondent



**Publisher / Business Address:**

Car Training Institute (CTI)  
A division of Euroforum Deutschland GmbH  
Toulouser Allee 27, 40211 Düsseldorf, Germany  
+49 211 88743-3000  
www.drivetrain-symposium.world  
E-Mail: [info@car-training-institute.com](mailto:info@car-training-institute.com)

**Do you want to showcase your expertise in drive technology or place an advert?** Contact [senel.celik@car-training-institute.com](mailto:senel.celik@car-training-institute.com)

**Project Manager:** Sylvia Zenzinger

**Layout:** ein|raum|buero – Kommunikationsdesign Kosmalla, Köln

**Copyright**

The articles in the CTI Magazine are published by Euroforum Deutschland GmbH. Literary copyright to all articles, illustrations and drawings contained therein is held by the relevant authors. No part of the publication may be reproduced by any means, mechanical, electronic or otherwise, without the express prior permission of the publisher and authors of the articles and drawings. The authors accept sole responsibility for the content of the articles.

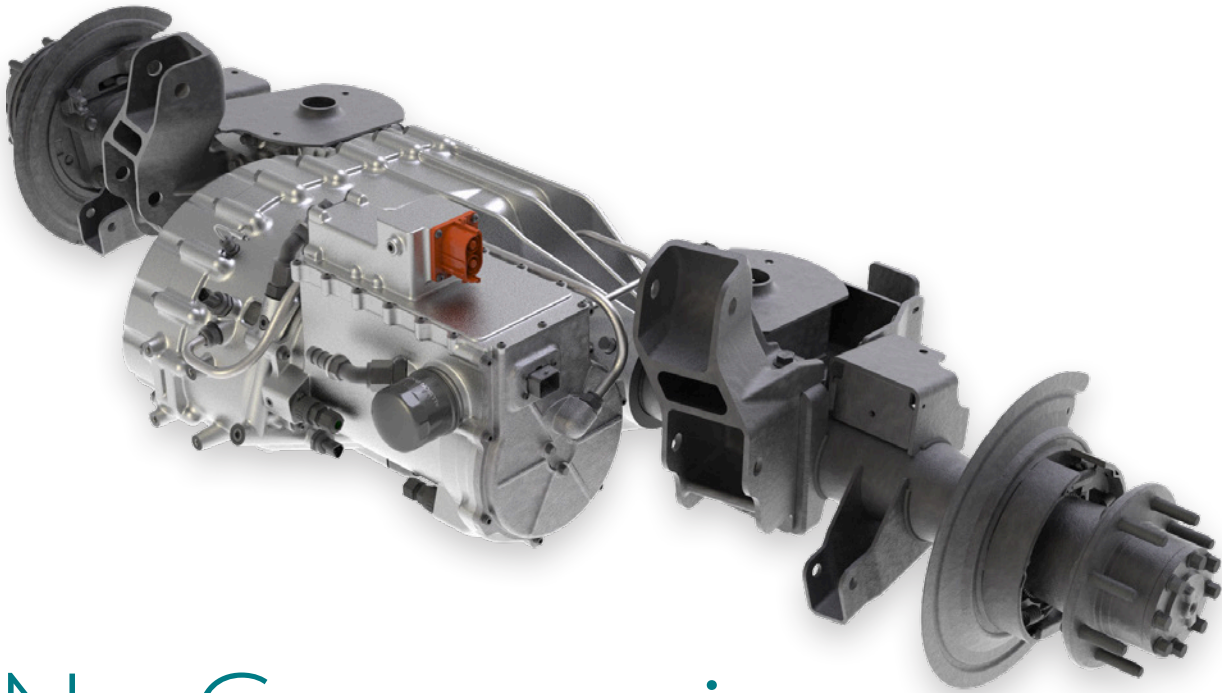

# No-Compromise Propulsion for the Heavy-Duty Electric Pickup

How a 2-speed integrated e-Beam axle removes the final barrier to practical heavy-duty electrification

Dan Ouwenga, Director – Product Management, Dauch

The promise of electric propulsion has always been straightforward: instant torque, smooth drivability, reduced NVH, and lower lifetime operating costs. For light-duty passenger vehicles, that promise has largely been delivered. But for the heavy-duty pickup truck - the Class 2b and Class 3 work vehicles that North American customers depend on to tow, haul, and perform under sustained load - first-generation electric architectures have fallen meaningfully short.

The technical challenge is the absence of a propulsion solution that can simultaneously deliver the launch torque, continuous power, and thermal robustness that HD truck customers require. A single-speed electric drive unit, however well-engineered, faces an inherent constraint: optimizing for peak launch torque forces a tradeoff against motor speed, mass, and efficiency at cruising conditions. The result is a system that can feel impressive off the line but struggles under sustained towing load which is precisely the use case that defines this segment.



Dauch's HD 2-speed electric rear e-Beam was developed specifically to address that tradeoff. The architecture integrates a nested 2-speed planetary differential within the axle housing that enables low-range torque multiplication without placing additional torque loads on the upstream components. In low range, the system delivers between 16,000 and 25,000 Nm of wheel torque against a gear ratio exceeding 35:1 - numbers that comfortably exceed the demands of the most aggressive HD towing and gradeability cycles. In high range, the system transitions seamlessly to a configuration optimized for efficiency and highway operation, with the motor running in its peak efficiency zone

The 2-speed design also enables the use of a smaller, lighter, high-speed induction motor - reducing diameter from a typical 230-260 mm down to 180 mm - which saves mass, improves packaging, and eliminates the supply chain and demagnetization risks associated with rare earth permanent magnet alternatives. A new flooded stator cooling system, using an integrated air gap sleeve to direct oil flow uniformly across the copper windings, enables sustained motor output at more than double the current density of conventional cooling approaches. The result is continuous rated power above 225 kW - not a peak figure, but a sustained capability this single e-Beam axle can maintain through a full Davis Dam or Baker Grade simulation without thermal derating.

The inverter also benefits from innovative cooling technology. A folded fin heat sink design allows direct oil cooling of the silicon carbide switching devices, reducing junction temperatures and improving continuous current capability. Benchmarked against competing architectures, this configuration delivers more than 50% improvement over a conventional isolated back plate module - meaning equivalent continuous power with significantly less silicon area, reducing cost while improving thermal margin.

Real-world validation has confirmed what the simulations predicted. A prototype 2-speed HD e-Beam was integrated into a RAM Heavy-Duty BEV conversion vehicle and subjected to a full validation program spanning dynamometer testing, cold weather operation at Aumovio's Brimley, Michigan development center, and hot weather SAE J2807 trailer tow simulation at the General Motors Yuma Desert Proving Ground in ambient temperatures exceeding 100°F. The vehicle successfully completed J2807 grade requirements at 26,000 lbs gross combined weight rating in two-wheel-drive - a demanding threshold that no comparable production-ready electric rear axle has achieved.

Thermal data captured during Davis Dam simulation at 45 mph in low range showed a 14-18% reduction in EDU operating temperatures compared to high range operation at the same load. That margin is not incidental - lower thermal load directly enables higher continuous power, longer towing duration, and greater calibration headroom. OEM customers present during vehicle demonstrations described the shift behavior as smooth and comparable to a traditional automatic transmission.

The technology is protected by a portfolio of 13 issued and pending patents, including two developed specifically for this application. Third-party freedom-to-operate searches have identified no blocking patents.

What this body of work ultimately demonstrates is that propulsion readiness can be removed from the list of barriers to HD electrification. The technical constraints that have prevented practical BEV and EREV adoption in the heavy-duty pickup segment - launch torque, thermal robustness under sustained load, production-viable shift quality - have been resolved. The remaining variables are market timing, energy storage and infrastructure solution readiness, and OEM program pacing. Those are real constraints, but they are external to the propulsion system. When the market conditions are right, Dauch is ready to provide an electrified HD solution. ●



# Innovation Powered by High-Fidelity Multiphysics Modeling

A Holistic System Optimization of BorgWarner's  
Next Generation Integrated Drive Modules

Dr. Arnaud Leblay, System Engineer Technologies & Innovation

Dr. Pascal David, Engineering Manager Technologies & Innovation

Eric Bourniche, Engineering Supervisor Technologies & Innovation

Adrien Bossi, System Engineer Technologies & Innovation

Harsha Nanjundaswamy, Engineering Director Technologies & Innovation

all BorgWarner PDS

## 1. Introduction

The development of cost effective, energy efficient and reliable Integrated Drive Modules (iDM) for electric vehicles is closely tied to optimization challenges. Addressing these challenges requires Multiphysics holistic approaches, that span magnetic, electrical, thermal, mechanical and fluid domains. Such an engineering methodology has been adopted by BorgWarner.

Across the industry, numerical methods such as Finite Element Analysis (FEA) and Computational Fluid Dynamics (CFD) are widely used to evaluate systems involving one or more physical phenomena within multiphysics analyses. These tools form the foundation for higher level modeling approaches such as Digital Twins, which enable full system vehicle simulations and the evaluation of electric machine control strategies under real driving conditions. Combined, these methods provide critical metrics that support decision making and guide technology development roadmaps.

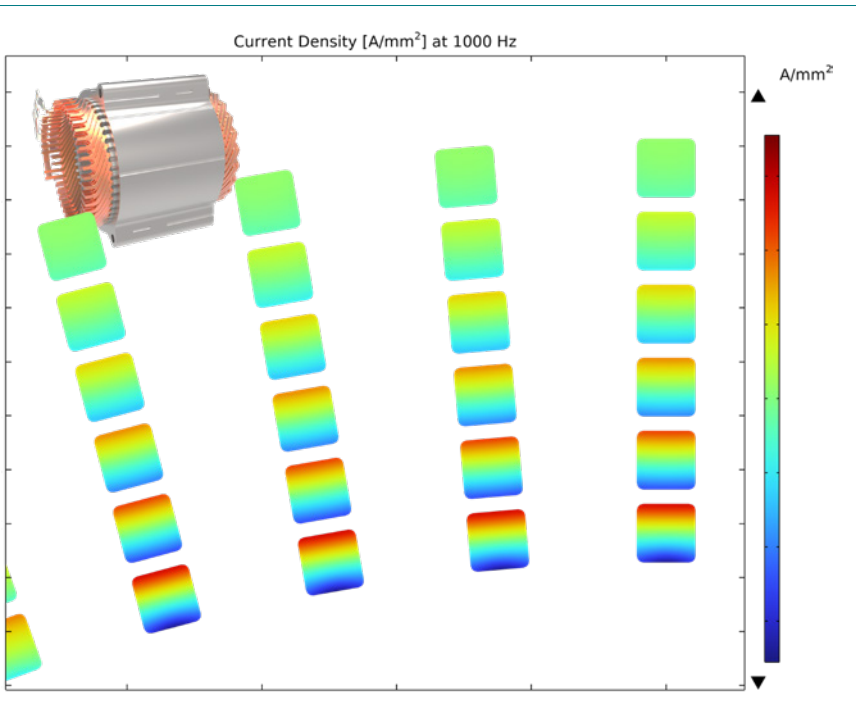

Figure 1: Current Density within the conductor cross section

One of these approaches concerns the methodology refinement applied to electric machine stator loss assessment. Stator loss can be split into iron loss and copper loss. The loss estimation enhancement is performed in collaboration with the Division of Industrial Electrical Engineering and Automation of Lund University in Sweden. The study was carried out in multiple steps to characterize the material properties, model the electromagnetic behavior, and finally perform transient thermal analysis.

The first step of the loss evaluation is to measure the lamination loss named iron loss and magnetic properties as magnetic hysteresis curves also known as BH curves. The experimental description can be found in [2].

The second step involves using the magnetic properties obtained in the first step and incorporating them into 3D Finite Element (FE) model of a complete wound stator under COMSOL Multiphysics, to assess the copper loss. The simulated impedances are compared to impedances measurements, and the relative error is not higher than 5% over a range of 100 Hz to 10 kHz.

BorgWarner PowerDrive Systems Technologies & Innovation group has developed a high fidelity, multiphysics based Digital Twin to support the development and innovation of iDM. The model has been rigorously validated through comparison with 78 physical signals sourced from both CAN communication channels and external sensor data [1]. In addition, some numerical models of sub components have been developed and validated in partnership with universities.

## 2. Methodologies Development for Deeper Insight

Methods form the foundation of engineering organizations. Sustaining innovation requires continuous improvement. Our methodology development strategy is grounded in in-house technical excellence, with experts actively contributing to Centers of Expertise to share best practices, lessons learned and identify improvement opportunities. This internal capability is further reinforced through strategic partnerships with academic institutions, start-ups, and technology providers.

Our Analytical Simulation Design plan [1] is formed by simulation cards whose inputs and outputs are bound to other cards to form a structured simulation framework. It enables pinpointing methodological gaps and areas where model predictions need refinement for greater accuracy and highlights phenomena that require deeper investigation through multiphysics analysis.

Those refinements are based on a dual approach combining advanced multiphysics modeling with high-quality experimental validation. The refinements can focus non-exhaustively on thermal, electric, magnetic, mechanical or fluid dynamics behaviors on overall iDM and its subcomponents.

The resulting current density with the conductor cross section can be observed on Fig. 1. The current density is not equally distributed resulting in the difference of losses within the conductors. A coupled electromagnetic thermal model was then employed to perform a transient analysis under adiabatic boundary conditions with the surrounding environment. The resulting temperature distribution after a 30 s transient event is presented in Fig. 2.

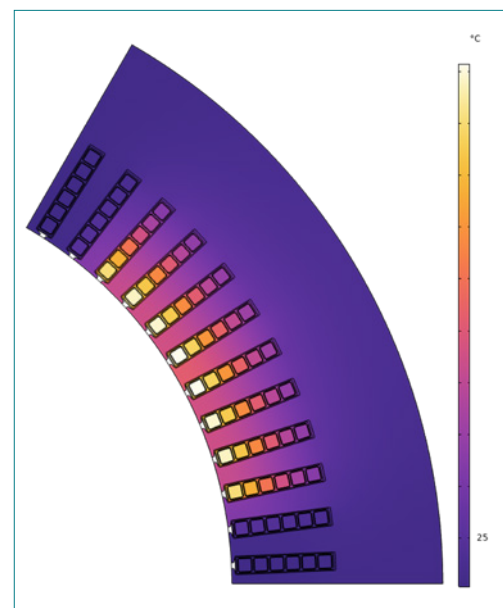

Figure 2: Temperature distribution after 30 s transient heat up in adiabatic conditions at 200 A(peak) and 1000 Hz

At system level, the inverter generates the current waveforms required to control the electric machine's performance and control strategies are developed accordingly to enhance overall system behavior. Using the previously detailed multiphysics approach enables a precise assessment of how those current waveforms impact electrical machine losses. This capability permits us to optimize the influence of innovative control strategies at inverter level on vehicle efficiency as demonstrated in [1], as part of our model driven innovation and optimization capability.

### 3. Model Driven Innovation and Optimization

Innovation and optimization of the iDM are supported by several key pillars.

One of them is Process and Design Development. Process and design tools are evolving in parallel, allowing engineers to explore innovative geometries and structures that were previously unattainable. Such optimization has been performed for a heatsink used in a power electronics device, resulting in complex geometry as shown on Fig.3. A cooling liquid is turbulently flowing inside the heatsink to cool two heat sources. The topology optimization has been set to minimize the temperatures of the heat sources and their temperature differences, while being below a pressure drop threshold. It defines the inner geometry. The synergy between 3D metal printing and numerical multiphysics topology optimization has become a key driver for innovative solutions.

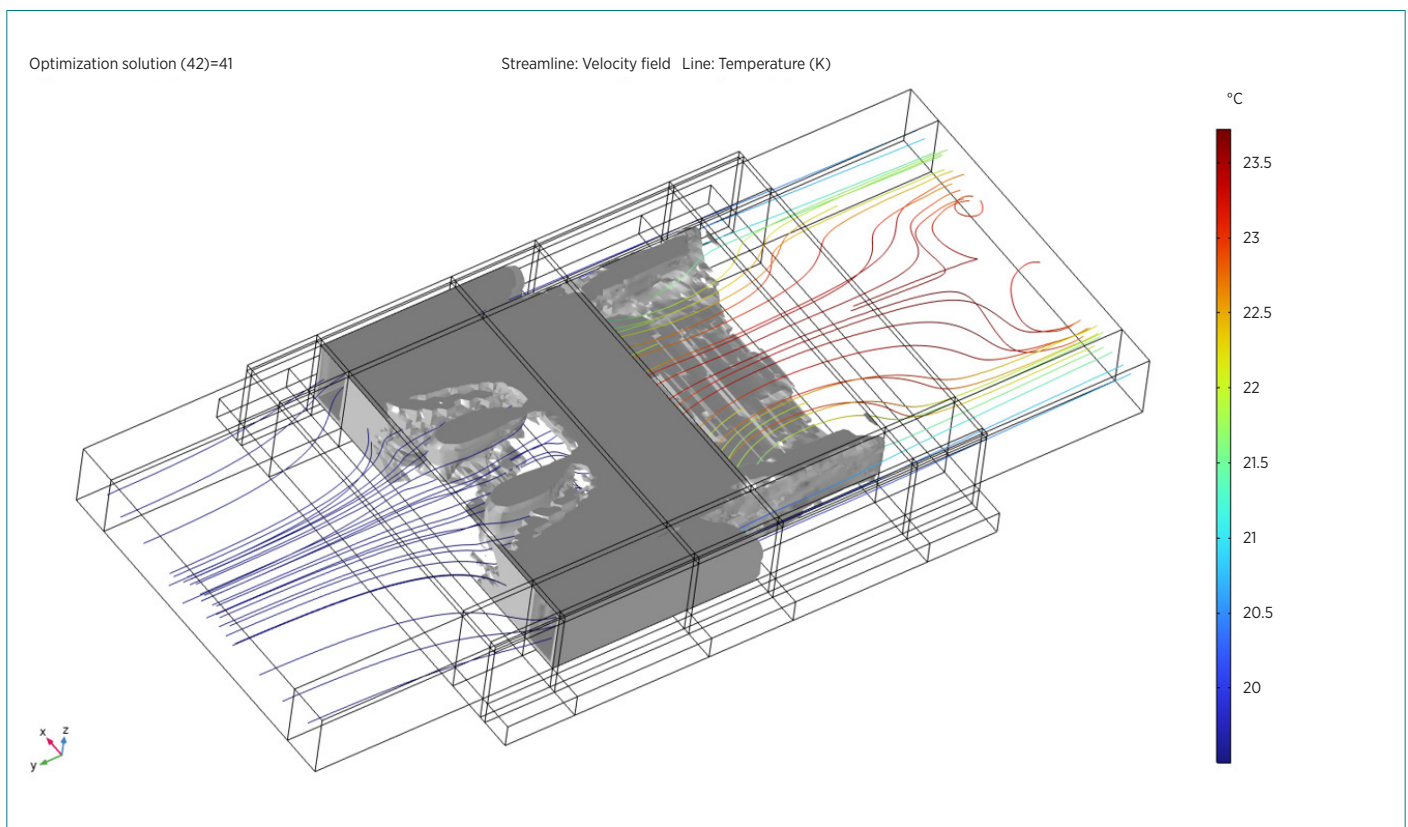

Figure 3: 41st iteration of 3D topology multiphysics optimization with a turbulent flow and two heat sources at the lowest surface

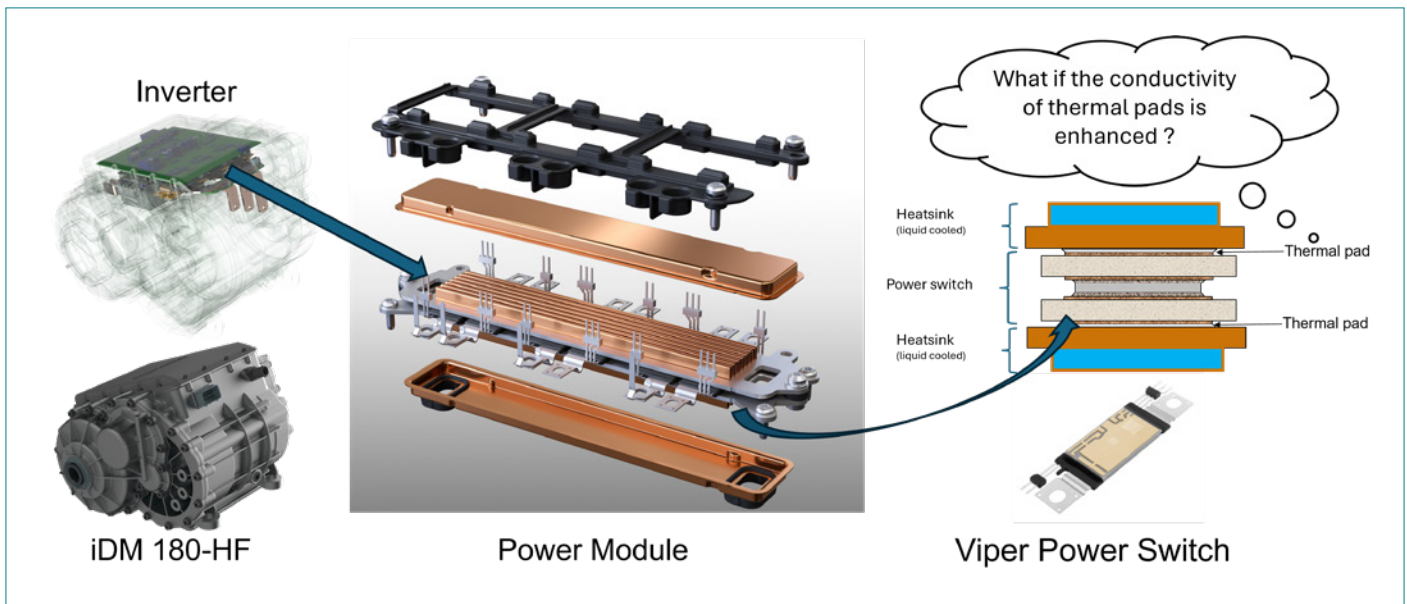

Figure 4: Integrated Drive Module iDM 180-HF, illustrating the inverter, its liquid cooled power module and its Viper power switches.

A second pillar is driven by AI breakthroughs in materials development. Historically, geometry/function and material selection have always been closely intricately in the development of components. Recent progress in artificial intelligence has significantly accelerated the growth of computational physics, chemistry, and materials science. These approaches leverage quantum mechanics to predict the atomistic structure of materials and translate it into macroscopic physical properties. Machine-learning-based computational physics now enables tailoring a material's atomic structure to meet specific performance requirements [3].

The third pillar is enabled by Digital Twin, which builds upon the first two approaches to optimize physical components and reinforce system-level foundations. This pillar focuses on the development and evaluation of innovative control algorithms and new iDM control strategies [4]. Although the inherent complexity of the vehicle system impacts simulation time, preliminary insights can often be obtained within only a few electrical cycles. While advanced control algorithms can be evaluated on a millisecond timescale, the full potential of Digital Twins is realized when combined with Reduced Order Models (ROMs), which significantly accelerate simulation performance.

#### 4. Use Case

The Digital Twin methodology makes it possible to extract high level, system wide performance indicators while still capturing the detailed behavior and interactions of individual components. Fig.4 illustrates this multiscale capability by zooming from the overall iDM architecture comprising the inverter, electric machine, and transmission, down to its subcomponents. Within the inverter, for example, the power module is modeled at a granular level. It consists of a stacked assembly that typically includes heatsink, thermal interface material (such as a thermal pad), and the power semiconductor switch. This detailed representation ensures that local thermal electrical behavior including parasitic phenomena are accurately captured and propagated up to system level performance metrics.

In this study, a vehicle Digital Twin embedding all multiphysics complexity into one single environment is employed. Electric machine, inverter and transmission models are interconnected and brought into a full vehicle representation. This includes detailed, non-exhaustively, thermal management, intelligent control strategies, thermal models, cooling system, lubrication.

Based on the vehicle Digital Twin simulation over a WLTP cycle, the results presented in Fig. 5 demonstrate the benefit of combining detailed component-level analysis with a system-level approach to assess global performance indicators.

The power switch temperatures can be accurately estimated at both granular and helicopter views. The evolution of the maximum power switch temperature over a single WLTC for three different thermal conductivities of the pad can be evaluated. The temperature profile exhibits alternating peak and cool-down phases, driven by several factors such as instantaneous current demand, DC-link voltage, switching frequency, and the applied control strategies. In addition, the absolute power losses are strongly influenced by the semiconductor die technology itself, which affects both switching and conduction losses. While many studies assume a constant coolant temperature at the heatsink inlet, vehicle thermal management has a major impact on component thermal behavior. Radiator valve actuation, front fan operation, and the overall thermal management architecture and control strategy directly influence the inlet coolant temperature evolution. Consequently, these

effects lead to different maximum temperature levels for the power electronic components, highlighting the importance of a fully coupled electro-thermal-system simulation approach.

## 5. Conclusion

The development of new numerical methodologies, validated through experimental investigations, enables a deeper understanding of coupled field effects, such as fluid, mechanical, thermal, electric, magnetic, and parasitic phenomena, and their impact on system behavior. By combining detailed component level multiphysics models with vehicle level driving cycles, BorgWarner's Digital Twin provides system wide performance indicators while preserving physical fidelity. This capability transforms simulation from an analysis tool into a decision making and optimization platform for architecture selection, material choices, and control strategies. The ability to assess component-level impacts at granular view while simultaneously maintaining a helicopter view at system level is a key enabler for rapid innovation and robust holistic optimization. ●

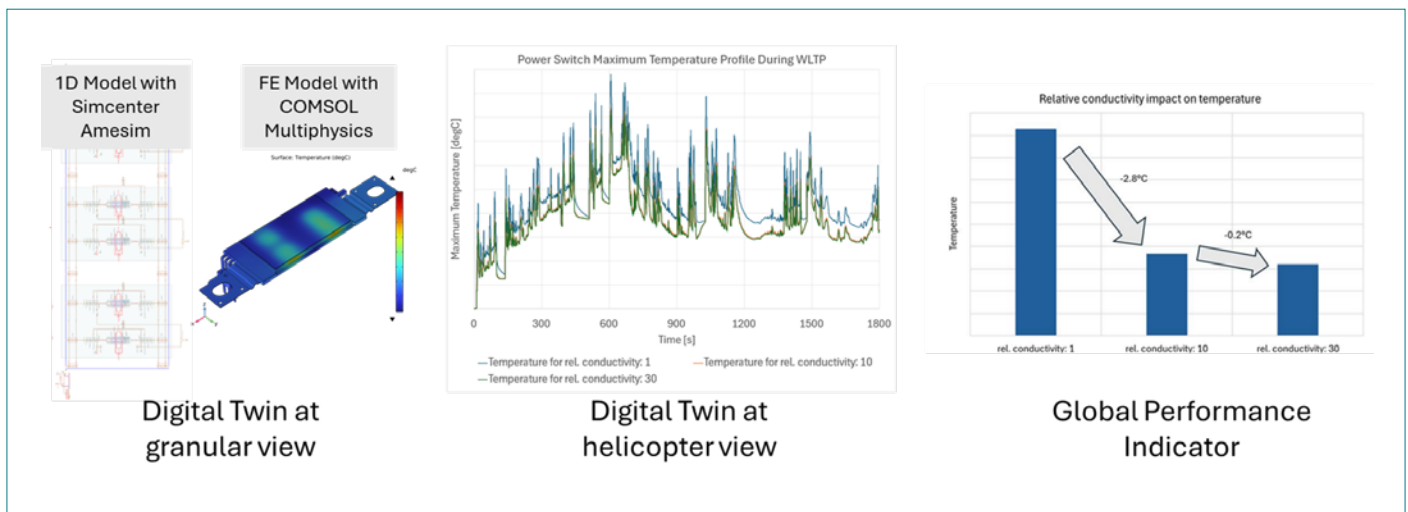

Figure 5: Overview of Digital Twin capabilities from granular to helicopter view providing global performance indicators at vehicle system level.

### Sources:

- [1] Bossi, A., Bourniche, E., Leblay, A., David, P. et al., „Digital Twin, A Multiphysics Numerical Tool Chain for Next Generation Electric Drive Design,” SAE Technical Paper 2025-01-8624, 2025.
- [2] Colombo, L., Reinap, A., Fyhr, P., Alaküla, M., „Enhancing Core Loss Tracking Accuracy in Stator Cores: A Comparative Assessment of Static and Dynamic Jiles-Atherton Model Formulations,” IEEE Transactions on Magnetics, vol. 61, no. 8, pp. 1-12, Aug. 2025, Art no. 7300512
- [3] Boziki, A. “HPC in Physics: Enabling Simulations and Accelerating Data Processing,” Presentation at SCynergy, April 2025.[3]
- [4] Nanjundaswamy, H., Deussen, J., Mayer, A. et al., “A Step Beyond Two, “Next Generation Multi-Level Traction Inverter with Clean Wave Technology”, 46th International Vienna Motor Symposium 2025, ISBN: 978-3-9504969-4-9



UNLOCKING  
YOUR  
ENGINEERING  
PUZZLES

CTI  
BOOTH  
D-7

# CUSTOMIZED COMPONENTS

for automotive applications

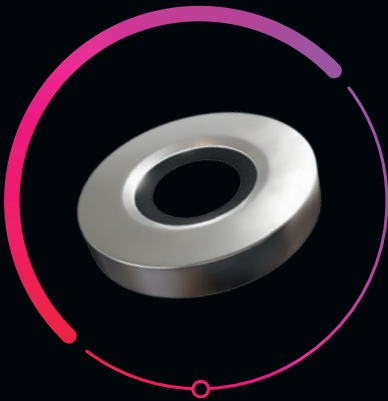

Seals



Bearings



Engineered  
fasteners



Precision components  
and assemblies



Torque components

**Low in leakage, friction, weight.  
High in performance over lifetime.**

[www.eqyo.com](http://www.eqyo.com)

A SAINT-GOBAIN BRAND

# Effective Solutions for Bearing Insulation to Prevent Electrical Erosion

Phillippe Pauchard, Application Engineer at DuPont (Switzerland)

Christoph Berger, Application Development Manager, DuPont (Germany)

## Electric erosion in bearings

Undesirable parasitic electrical currents in traction motors can pass through roller bearings and cause damage known as electrical erosion. This phenomenon is characterized by electrical discharges between the rolling elements and the bearing raceways, leading to the formation of spot welds at the contact surfaces. During operation, these spot welds repeatedly break apart, generating abrasive metal debris that accelerates wear and can result in premature bearing failure.

Electrical erosion can affect bearings in various types of electric motors, including AC, DC, servo, and stepper motors, and is most observed in high-speed motors, electric vehicle regenerative braking systems, and motors controlled by variable frequency drives (VFDs). In severe cases, electrical erosion can lead to premature motor failure, posing safety risks, increasing downtime, and resulting in significant repair and replacement costs.

## Common solution

A common mechanical solution to prevent electrical erosion is the use of hybrid ball bearings with ceramic rolling elements. These bearings provide electrical insulation between the rotor and the housing, thereby eliminating the conductive path required for electrical discharge and subsequent erosion. However, it is important to note that hybrid ceramic ball bearings can be more expensive than standard steel bearings. For roller bearings, or for bearings designed to carry higher loads and therefore employing larger rolling elements, hybrid solutions are either significantly more costly or not commercially available.

A more economical approach is to electrically insulate standard steel bearings. Ceramic-coated bearings, typically using aluminum-oxide coatings applied to the inner or outer ring, effectively block DC and low-frequency stray currents. Coating thicknesses in the range of approximately 100–200  $\mu\text{m}$  are commonly rated for 1–3 kV DC breakdown voltage. However, due to their capacitive behavior and limited mechanical robustness, such coatings may provide reduced protection against high-frequency electrical discharge in modern motors controlled by variable frequency drives (VFDs).

## Insulating Sleeve Idea

To effectively protect against high-frequency electrical discharge and avoid capacitive effects, a thicker electrical insulation barrier is required. Polymeric insulating sleeves, typically with thicknesses in the range of 1 to 2 mm, can be used for this purpose. The choice of polymer, however, is constrained by its dimensional stability at the peak operating temperature of the application. For EV traction motors, peak temperatures typically specified by OEMs are around 150 °C. While many polymers do not melt until higher temperatures, they often exhibit a glass transition temperature below 150 °C, which compromises dimensional stability at elevated operating temperatures.

The use of glass-fiber reinforcement can help mitigate this effect and increase temperature capability; however, the presence of glass fibers may introduce abrasive wear on metallic counter surfaces, such as aluminum housings. To address these limitations, a high-temperature polymer is required that maintains dimensional stability at elevated temperatures without the need for fiber reinforcement.

## Vespel® polyimide: Balancing electrical insulation and dimensional stability

Vespel® S is a sintered polyimide that exhibits no observable glass transition temperature or melting point. Its exceptional high-temperature resistance allows it to be used as an insert in die-cast aluminum components. This unique property is particularly important for applications involving high mechanical loads and elevated temperatures, such as traction motors operating in critical drive modes or under malfunction conditions.

Vespel® polyimide insulating bearing sleeves can be used to electrically insulate the rotor from the housing, thereby suppressing discharge currents. They provide a versatile and cost-effective solution for mitigating electrical corrosion in electric motor bearings and can be installed during final assembly by press-fitting standard ball bearings. A Vespel® polyimide insulating layer with a thickness between 1 and 2 mm offers robust electrical insulation by significantly increasing electrical impedance. This effectively attenuates high-frequency currents traversing the bearing, thereby reducing the risk of electrical erosion. In addition, Vespel® polyimide exhibits mechanical damping properties that may help reduce noise, vibration, and harshness (NVH) in electric motor systems.

### Manufacturing Vespel® bearing Sleeve

Vespel® polyimide components are manufactured using a powder-based direct forming process followed by high-temperature sintering. In this process, polyimide powder is compacted at room temperature into a green part, which is then sintered to produce a dense, non-meltable polyimide component. Unlike injection-molded parts, sintered components do not exhibit structural weaknesses such as weld lines or injection points. Depending on the final tolerances required for the assembly, the sintered parts can be machined using conventional metalworking equipment, including grinding operations, enabling the production of high-precision finished components.

### Assembly of Vespel® sleeve onto the bearing

The Vespel® sleeves can be installed by press-fitting them onto either the rotor shaft or one of the bearing rings (Figure 1). In all configurations, standard steel ball bearings can be used in combination with the Vespel® sleeve, thereby eliminating the need for costly ceramic rolling elements such as those used in hybrid bearings.

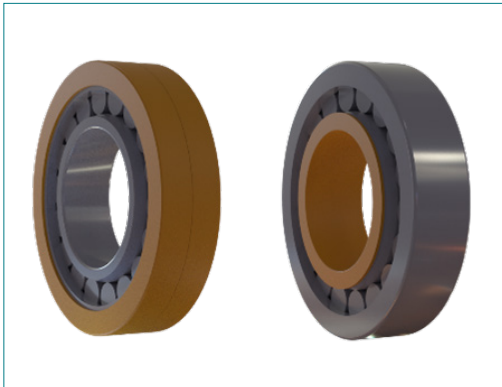

Figure 1: Vespel® bearing insulation sleeves can be installed on the outer diameter (left) or on the inner diameter of the bearing (right)

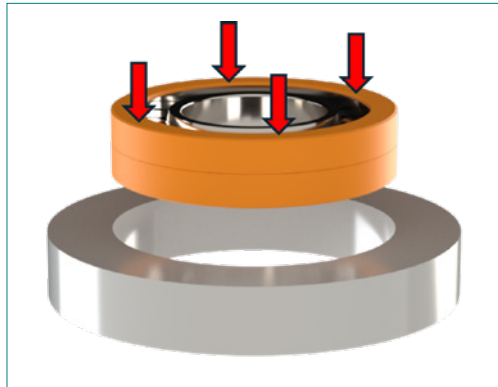

Figure 2: Assembly of bearing has been done on a 88 mm diameter roller bearing (NU209)

### Assemble Bearing Equipped with Vespel® Sleeve

The assembly of bearings equipped with a Vespel® sleeve was evaluated by Durkopp, a manufacturer of roller bearings. In this study, Durkopp ground the outer diameter of several test bearings to achieve press-fit conditions ranging from +5  $\mu\text{m}$  clearance to 50  $\mu\text{m}$  interference. During assembly (Figure 2), the press-in force was measured using a load cell.

The maximum insertion force measured during assembly is shown in Figure 3 for various interferences. An assembly force of up to 9,300 N was recorded at the highest interference fit, with no observable damage to the Vespel® sleeve.

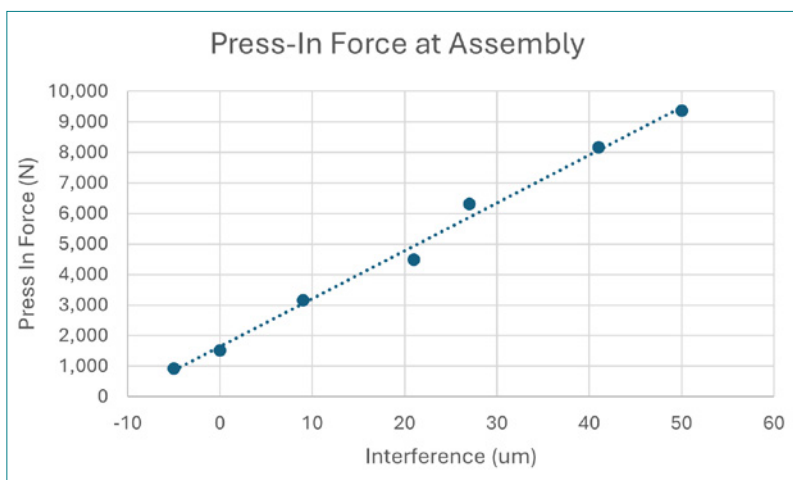

Figure 3: Maximum insertion force measured during assembly for various interference



### Electrical Properties Comparison with Ceramic Bearing

Various tests have been conducted to support the use of Vespel® sleeves in addressing electrical corrosion issues. The electrical impedance was measured by IMKT (Institut für Maschinenkonstruktion und Tribologie at Leibniz Universität Hannover). The results indicate that the electrical insulation performance of Vespel® SP-1, while slightly lower than that of hybrid bearings, remains within the same order of magnitude and is significantly higher than that of ceramic-coated bearing solutions, even when compared with the thickest ceramic coating layer (Figure 4).

### Static and Dynamic Load Testing

To demonstrate the mechanical resistance of the Vespel® sleeve, a test was conducted on an 88 mm-diameter roller bearing (NU209). A radial load of 10 kN, which is significant for a standard roller bearing, was applied for 24 hours at a temperature of 140 °C (Figure 5). The circularity of the Vespel® sleeve outer diameter was measured before and after the test. The results indicate that the circularity increased only from 3.7 µm to 5.2 µm, remaining well below the supplier’s specified limit of 9 µm for the bearing. These results demonstrate the excellent dimensional stability and mechanical resistance of Vespel® components under demanding operating conditions.

A similar test was conducted at a rotational speed of 3,000 rpm. In this case, the test was performed under a higher radial load of 25 kN, but at room temperature. The results indicate that the circularity increased only from 2.9 µm to 7.0 µm after the test, which remains below the supplier’s specified limit of 9 µm.

### Summary

Electrical erosion is a major reliability concern in modern electric motors, particularly in high speed and VFD controlled applications where high frequency discharge currents accelerate bearing degradation. Conventional mitigation solutions such as hybrid ceramic bearings and ceramic coated bearings offer partial protection but are often constrained by high cost, limited availability, or reduced effectiveness under high frequency electrical stress.

The results presented in this study demonstrate that Vespel® polyimide insulating sleeves provide an effective and economical alternative for electrically insulating standard rolling bearings. By introducing a thick polymeric insulation layer, Vespel® sleeves significantly increase electrical impedance, thereby attenuating high frequency discharge currents and reducing the risk of electrical erosion. Electrical testing confirms insulation performance comparable in magnitude to hybrid bearings and clearly superior to ceramic coated solutions.

Mechanical testing under representative load, speed, and temperature conditions further confirms the excellent dimensional stability and mechanical resistance of Vespel® sleeves. Their compatibility with standard bearings and conventional press fit assembly processes makes this solution particularly attractive for scalable industrial and automotive applications. Overall, Vespel® insulating sleeves offer a robust, versatile, and cost-effective approach to improving bearing durability in electric motor systems.

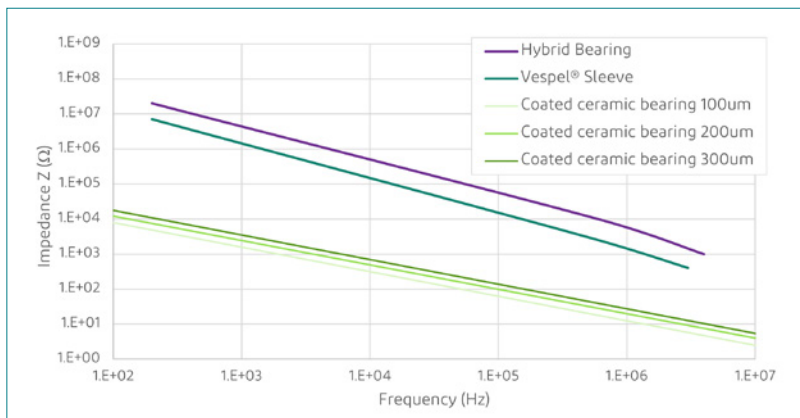

Figure 4: Impedance measurement on various bearing types; Hybrid bearing, Ceramic coated and Vespel® sleeve

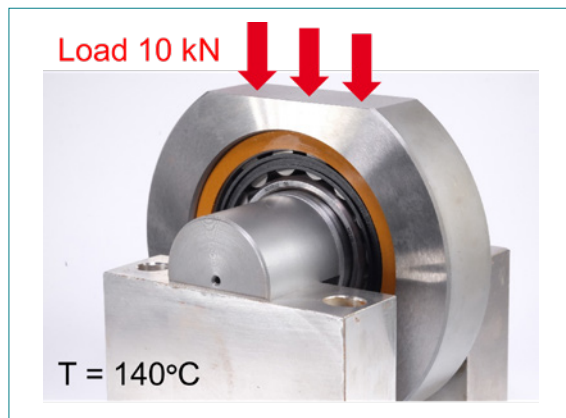
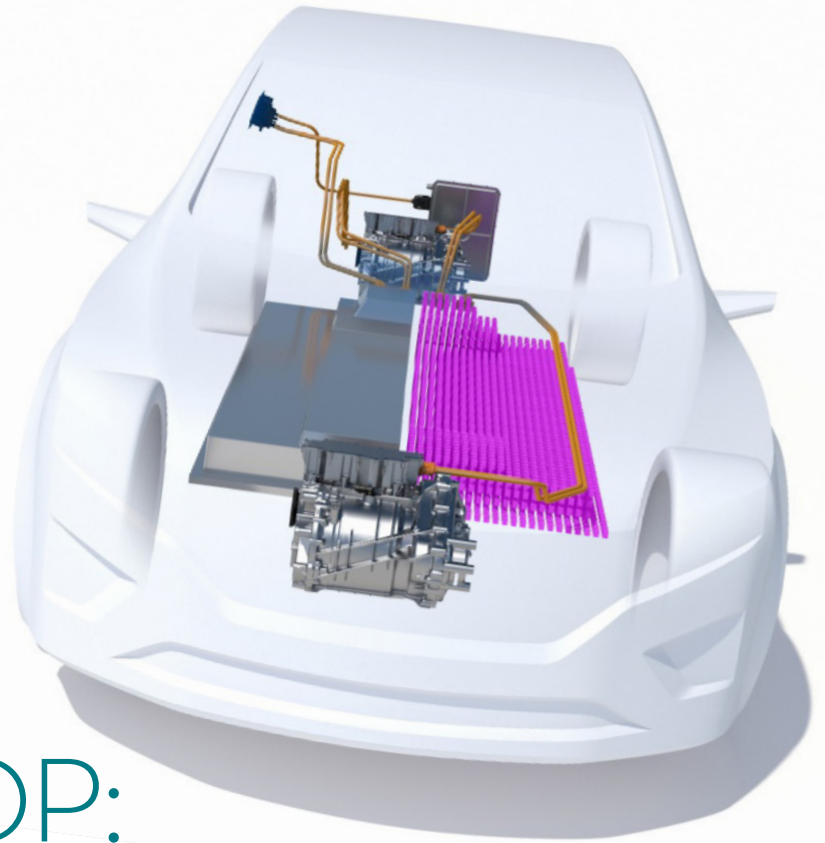

Figure 5: Test rig used to evaluate dimensional stability of the Vespel® parts with a radial load 10 kN at 140°C for 24h.

©2026 DuPont. All rights reserved. DuPont™, the DuPont Oval Logo, and all trademarks and service marks denoted with ™, SM or ® are owned by affiliates of DuPont de Nemours, Inc. unless otherwise noted. DuPont believes this information to be reliable. It may be subject to change as additional knowledge and experience are gained. It is not intended as a substitute for any testing you may conduct to determine for yourself the suitability of our products and information for your particular purpose. Since conditions for use are outside the DuPont’s control, DUPONT DE NEMOURS, INC. AND ITS AFFILIATES MAKE NO WARRANTIES, EXPRESSED OR IMPLIED, INCLUDING BUT NOT LIMITED TO WARRANTIES OF MERCHANTABILITY OR FITNESS FOR A PARTICULAR PURPOSE AND ASSUMES NO LIABILITY IN CONNECTION WITH ANY USE OF THIS PRODUCT AND INFORMATION. This information is not intended as a license to operate under or a recommendation to infringe any trademark, patent or technical information of DuPont or other persons covering any material or its use.



# Faster to SOP: Virtually and with Smarter Testing

Batteries are the core component of electrified vehicles. However, conventional approaches, that heavily rely on physical prototyping and extensive testing, are too slow and costly for the pace that is demanded by the market. IAV implemented virtual-driven processes with smart testing achieving development time and cost reductions of up to 30 %.

Dr. Reik Laubenstein, Engineer, IAV Automotive Engineering Inc.

Dr. Johannes Werfel, Team Manager, IAV GmbH

## Methodology

Often the development of EV batteries heavily relies on continuous and frequent hardware updates and extensive durability testing that proves challenging considering timelines and associated costs. Main obstacles are scarce component availability (e.g., cells) in early stages, and expensive & time-consuming testing loops. Shifting towards virtual development can mitigate these challenges, but these methods often fall short on capturing the complex interactions between the different domains (design, thermal management, function). However, IAV developed a project-proven methodology that focuses on early application of predictive component models, which can be coupled and used to predict the behavior of the higher-level system with complex

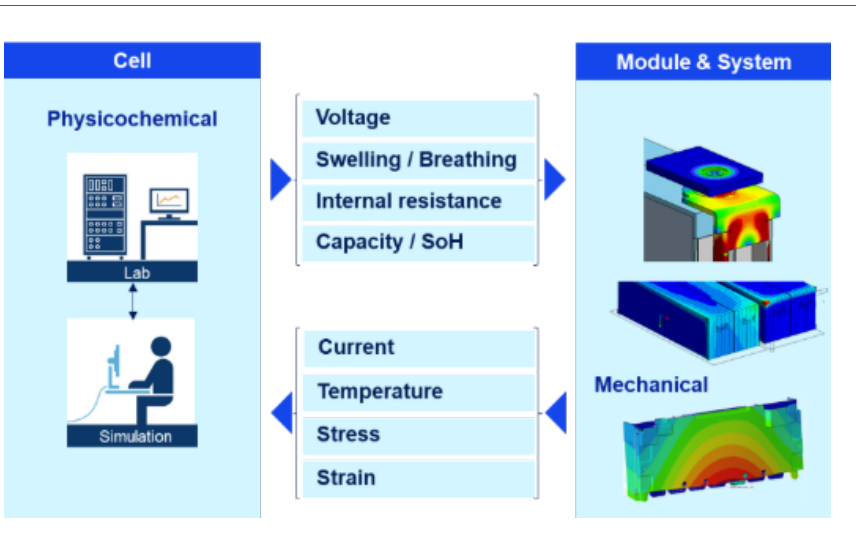

Figure 1

interactions (e.g., module or pack, see Fig. 1) and thus, reduce expensive prototyping and testing during. The foundation of this “shift-left” approach are electro-physico-chemical models (EPCM) that describe the electrical, thermal and mechanical behavior of the cell. Due to the scarcity of physical cells at early stages of development, our internal tools and workflows enable deriving theoretical cell design parameters with minimal input to construct baseline cell models, that are continuously optimized with further progress. To further increase efficiency, we established a smart testing approach based on reinforcement learning to characterize cells in early stages, by utilizing neural networks to balance the testing effort and model accuracy. It has been shown that 60%

of all relevant operational points can be sufficient to reach a comparable accuracy of a model that utilizes all measurement points of the measurement matrix. Once established, the EPCM can be seamlessly integrated into the aforementioned domains to enable further development and optimizations by the respective domain experts. This is realized via the versatile virtual battery testbench (VBT) framework developed by IAV and allows for model-in-the-loop (MiL) investigations in various other established toolchains, which are being utilized by various domain experts throughout the whole V-process (e.g., thermal management, BMS function development, exploration of mechanical constraints) and without requiring physical cell samples.

### Application

A critical aspect in battery systems development is the ability to accurately understand and predict

battery aging under realistic operating scenarios. In our approach the EPCMs are capturing structural changes on particle level (e.g., Li plating, SEI growth, particle cracking) in response to the change of the boundary conditions of the system via interaction through the VBT. This was applied in a representative project: failures in battery modules were detected at roughly half the targeted lifetime. A simulation-driven approach utilizing the cell model, completed within six weeks identified critical pressure accumulation caused by the interaction of cell aging, swelling, and module boundary conditions. Early virtual integration is estimated to have saved more than six months of testing and prototyping.

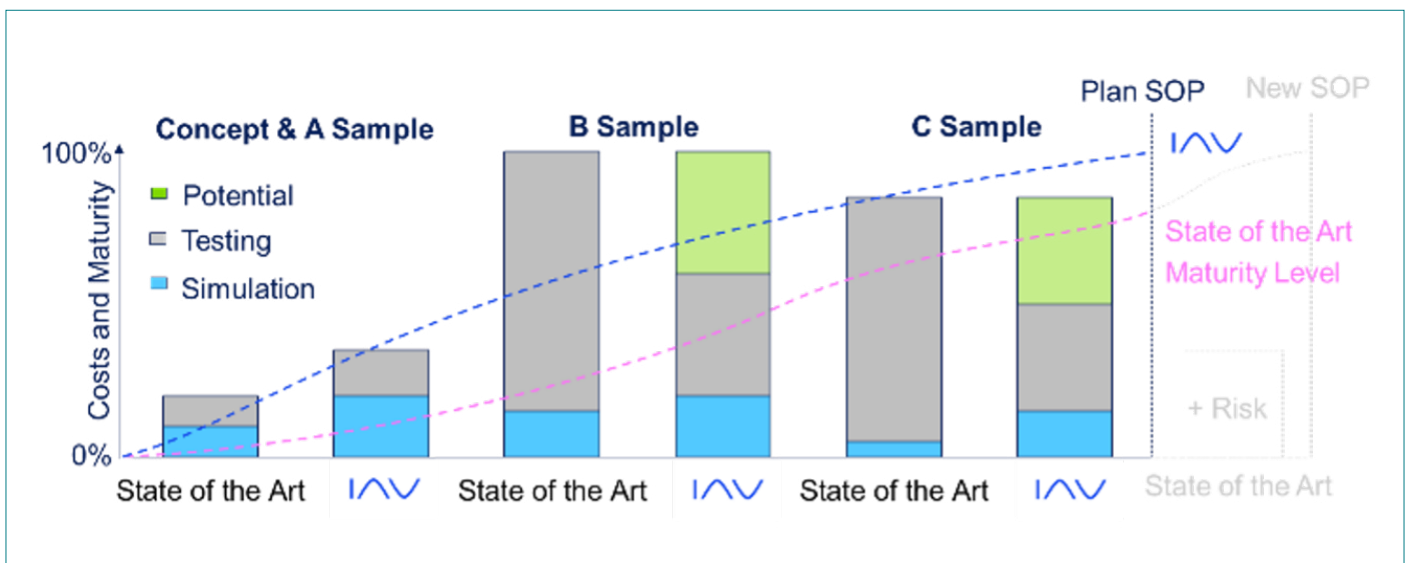

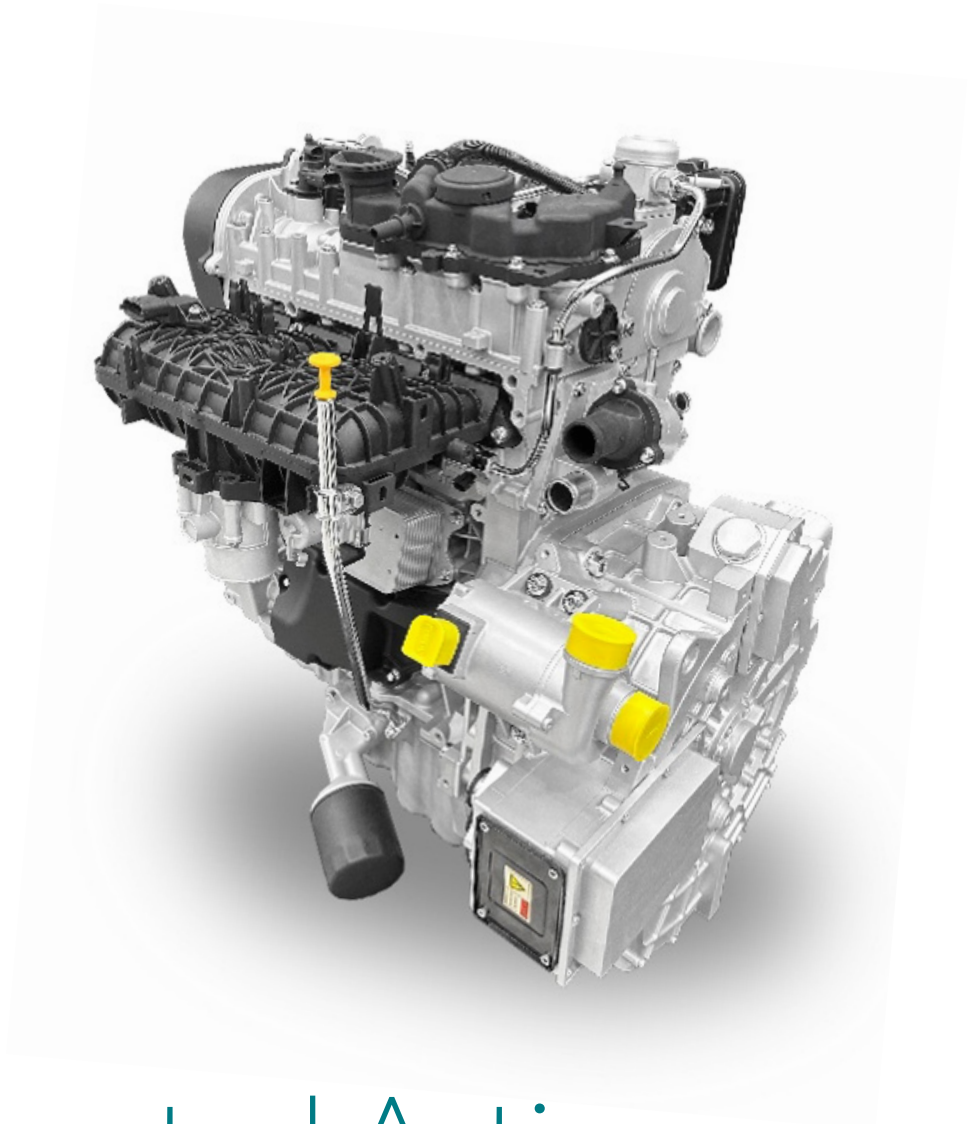

# JJE Integrated Active NVH Cancellation Range Extender Technology

Dr. Cao Yang, Engineering Executive, Company: JJE Technologies Co.,Ltd.

The range extender, as a critical enabler for new energy vehicles, has long been challenged by the inherent trade-off between compactness, noise, vibration, and harshness (NVH), and system cost. This article presents JJE's Integrated Active Cancellation Range Extender Technology, a next-generation system that fundamentally redefines the mechanical and control architecture of hybrid power units.

**The technology is built upon three core innovations:**

- ▶ direct-coupled, oil-cooled coaxial architecture that eliminates the flywheel and all torsional damping elements;
- ▶ an active torsional vibration cancellation strategy that generates an opposing torque wave relative to the generator torque profile to neutralize engine vibration;
- ▶ a novel method for determining engine crankshaft position using the motor resolver signal without additional sensors.

Together, these innovations enable a system in which speed fluctuation is reduced by over 50% and body vibration by more than 85%, while achieving unprecedented mechanical simplicity and robustness validated in full-scale mass production. This paper details the design philosophy, implementation, and performance validation of the JJE range extender, establishing it as a benchmark for future integrated hybrid powertrains.

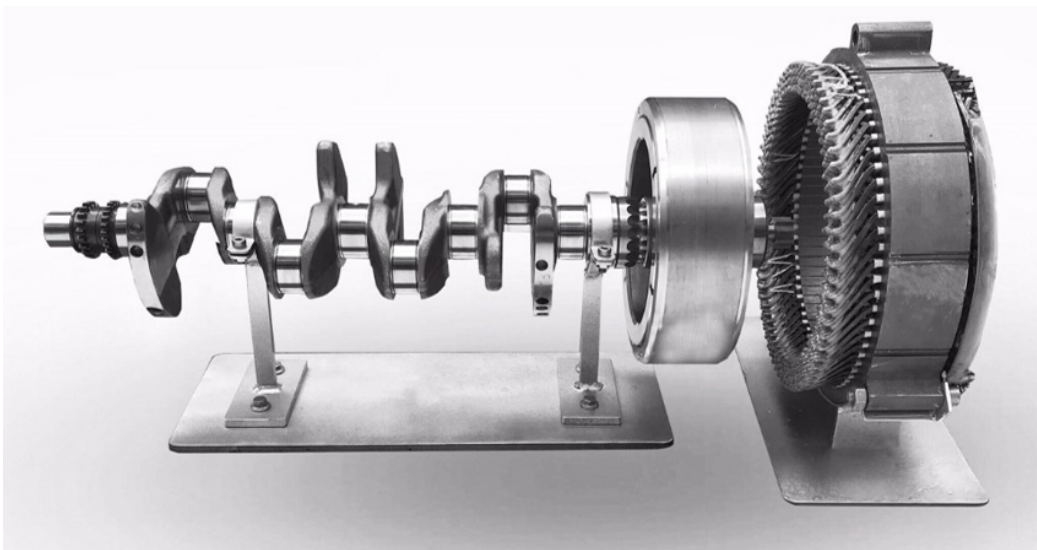

Fig. 1 JJE Direct-Coupled Coaxial Architecture

**Introduction**

Conventional range extenders inherit the complex architecture of traditional internal combustion engines, including flywheels, torsional dampers, and numerous sensors and communication networks, to manage noise and vibration. These components add weight, cost, and packaging complexity, while noise and vibration still compromise passenger comfort when the engine switches between operating points.

Moreover, delays inherent in conventional speed sensors and communication buses limit the effectiveness of vibration cancellation strategies, preventing precise tracking of the generator's vibration waveform.

After more than a decade of development, JJE has overcome these limitations by introducing a fully integrated range extender—a step-change innovation. The concept combines deep mechanical integration with intelligent active control. The result is a system in which the engine crankshaft, generator rotor, and oil pump rotor are rigidly connected along a common axis, allowing the generator to act as an active actuator that cancels vibration at its source—the internal combustion engine.

**Direct-Coupled Coaxial Architecture**

The first innovation is the system's mechanical design: a rigid coaxial connection between the engine crankshaft, generator rotor, and oil pump rotor, without any flywheel or torsional damping elements (Fig. 1).

In conventional designs, flywheels and torsional dampers are used to smooth engine torque before it reaches the generator. However, these components add rotational inertia, reduce dynamic response, increase axial length and system weight, and introduce wear-prone elements.



In JJE’s architecture, these components are intentionally eliminated. The crankshaft output flange is directly coupled to the motor shaft, with the oil pump rotor mounted at the rear. The entire rotating assembly behaves as a single rigid body with minimized moment of inertia. As a result, the system achieves a weight reduction of approximately 11 kg and a significant cost reduction.

The removal of flywheel and damping elements introduces an NVH challenge: engine torque pulsations act directly on the generator rotor. This is addressed by the second innovation—the active control strategy.

### Active Torsional Vibration Cancellation (ATVC)

The rigid, low-inertia architecture is made feasible by the development of active torsional vibration cancellation (ATVC). The core concept is to treat the generator not only as an electrical load, but also as a torque actuator capable of producing a precisely controlled counteracting torque waveform.

JJE’s system implements an active control algorithm (Fig. 2). Using real-time crankshaft position data, the controller predicts the engine’s instantaneous torque contributions. Based on this prediction, an opposing torque waveform is synthesized and superimposed onto the generator output torque. This effectively creates a virtual torsional damper with zero mass and no mechanical wear.

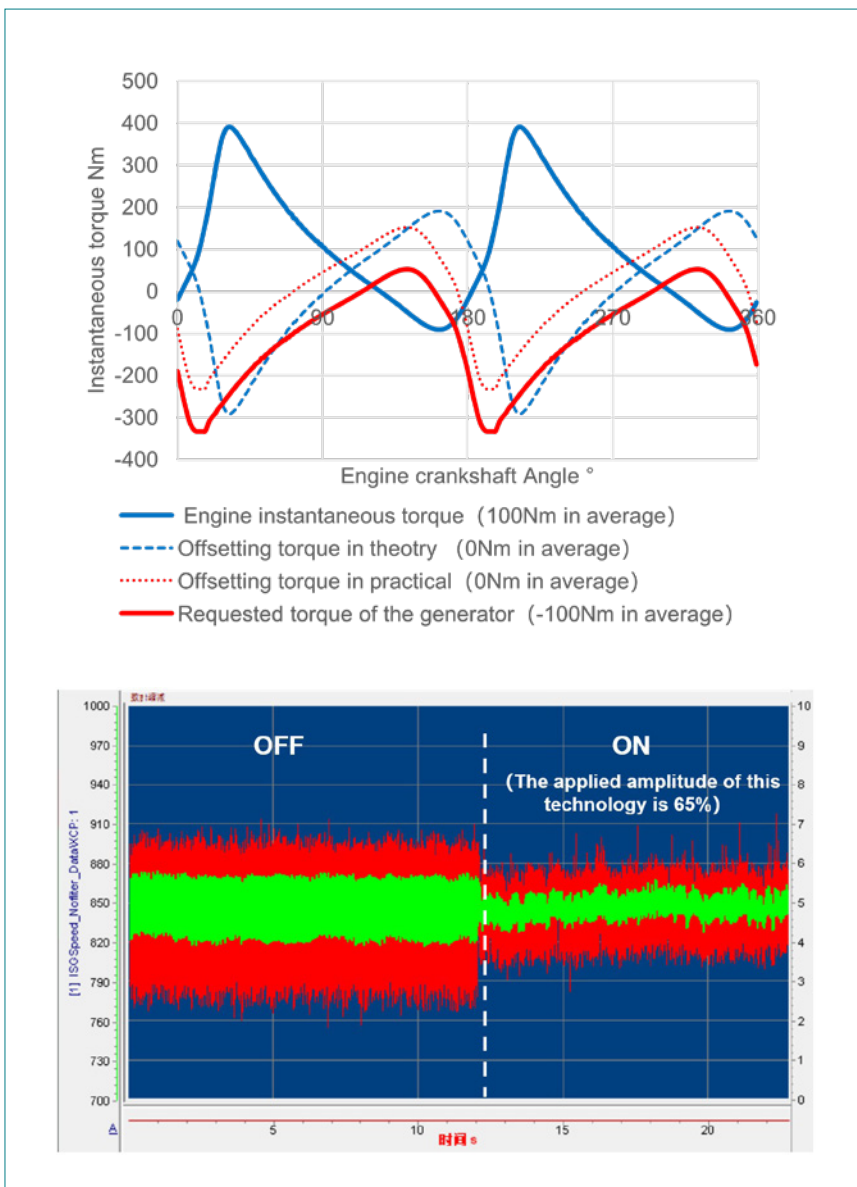

Fig. 2 JJE Active Torsional Vibration Cancellation

The system reduces speed fluctuation by more than 50% compared to a passive damping solution. More importantly, vibration transmitted to the vehicle body is reduced by over 85%, delivering a substantial improvement in NVH performance.

### Engine Crankshaft Position Detection via Motor Resolver

High-performance vibration cancellation depends on accurate, zero-delay measurement of crankshaft position. This innovation eliminates the need for conventional engine position sensors entirely.

In JJE's system, the motor rotor is rigidly coupled to the engine crankshaft, meaning both rotate at the same speed. The motor resolver inherently provides precise rotor angular position, which directly corresponds to the crankshaft position.

A dedicated method was developed to derive crankshaft position from the resolver's raw sine and cosine signals at high refresh rates within the generator controller. During the first engine cycle after start-up, a calibration algorithm identifies piston positions by analyzing resolver signals in combination with the known engine firing order. Once synchronized, the resolver-derived angle is distributed within the controller with effectively zero delay, meeting the stringent requirements of the cancellation algorithm.

This approach eliminates the need for crankshaft position sensors, associated wiring, connectors, and signal conditioning circuits, improving system robustness while reducing cost and complexity. The solution has been fully validated in mass production.

### System Integration and Production Validation

This system has been deployed in multiple mass-production vehicles, including the Beijing Auto BJ40E and BJ60E. Notably, the BJ40E has become one of the best-selling off-road SUVs in the Chinese market since its launch in April 2025.

### Conclusions

JJE's Integrated Active Cancellation Range Extender Technology represents a significant breakthrough in range extender design. By combining a direct-connected architecture, active torsional vibration cancellation, and sensorless crankshaft position detection, JJE has created a system that is mechanically simpler, more compact, and substantially superior in NVH performance compared to conventional solutions.

With robustness proven in mass production, this integrated system is well positioned to enable the next generation of quiet, efficient, and cost-effective hybrid and range-extended vehicles. ●



The system supports applications up to V8 engines paired with the SD290 generator (stator diameter = 290 mm), demonstrating scalability across a wide range of power levels.

# Where Mobility Innovation Meets Industry Access

Alan Amici, GAMIC Leadership Team

Visit GAMIC at the CTI Symposium in May

The Global Automotive & Mobility Innovation Challenge connects vetted startup innovation with the people and organizations shaping North America's mobility future — at no cost and with no equity taken.

Since 2008, GAMIC has served as the bridge between promising early-stage companies and the automotive and mobility leaders best positioned to help them scale. The program doesn't just offer visibility — it offers traction. Startups accepted into GAMIC gain access to expert mentorship, investor exposure, and direct engagement with OEMs, Tier-1 suppliers, and decision-makers who can move things forward.

What makes GAMIC different is what it removes. There are no application fees and no equity requirements. For a founder navigating one of the world's most complex industries, that removes a real barrier. Instead of spending time and capital on traditional access channels, GAMIC participants get a curated, high-trust platform designed specifically for the mobility sector — backed by SAE International and supported by a global network built over nearly two decades.

## For Founders: A Fast Track to the Right People

Getting in front of the North American mobility industry isn't just about having a strong technology — it's about knowing where the doors are. GAMIC gives founders that entry point.

Finalists are selected through a rigorous, industry-vetted process, which means the exposure they receive carries real weight. Being named a GAMIC finalist signals something meaningful to investors and partners: this team has been evaluated, not just promoted. That validation matters in a market where noise is constant and trust is earned slowly.

Beyond the competition itself, participants benefit from hands-on coaching, a global peer community, and the kind of strategic feedback that typically requires years of relationship-building to access. Alumni have gone on to raise capital, secure pilots, and be acquired — outcomes that trace directly to connections made through the program.

## For Sponsors: First Access to Vetted Innovation

For organizations that need to stay ahead of what's emerging in mobility, GAMIC offers something internal pipelines rarely provide: a curated, global view of early-stage innovation that's already been filtered for potential.

Sponsors aren't just providing support — they're gaining strategic positioning. Being present in the GAMIC ecosystem puts your brand in front of founders, investors, and fellow industry leaders in an environment built around genuine collaboration. Sponsorship includes premium brand placement, direct access to competition participants, and the opportunity to engage through judging, mentorship, and event presence.

In an industry where the next significant technology shift could come from anywhere in the world, GAMIC gives sponsors early visibility into what the broader market hasn't seen yet..

## What's Next

GAMIC runs annually, with each new cycle bringing a fresh cohort of global startups competing for recognition and access to the North American mobility market. If you're building a mobility technology — or looking to stay close to what's emerging — applications for the next competition open in the fall. ●

## GAMIC BY THE NUMBERS

- › 18 years connecting global mobility startups to the North American industry
- › \$2 billion+ USD raised in investment and acquisitions by GAMIC alumni
- › 1,000+ startup alumni from around the world
- › Backed by SAE International — reaching 15,000+ mobility professionals at WCX annually
- › Zero cost to apply. Zero equity taken.

Explore the competition and sponsorship opportunities at [gamicevent.org](http://gamicevent.org)

# High Performance, Magnet-Free Electric Motors

Rory Brogan, Founder & CEO, Torev Motors

Torev Motors develops wound rotor axial flux motors for automotive and defense vehicles.

## Building on proven, scalable technologies

Torev's architecture builds on technologies already proven in production vehicles, including wound rotor motors used by companies including BMW and Nissan, and axial flux used by companies including Mercedes and Ferrari. By integrating these approaches, Torev aims to deliver motors capable of up to 2x the torque density of radial flux motors, that use 0 kg of permanent magnetic material, and that saves up to an estimated 50% on active material costs.

## 1.1 How it Works & Performance

Wound rotor motors, also called externally excited motors, replace permanent magnets with electrically excited coils. These motors offer greater torque and almost constant power at high speeds [1], wide efficiency maps stemming from direct control over the rotor fields, and material cost efficiencies from using no permanent magnets. Historically, these systems introduced greater weight, rotor thermal cooling requirements, and additional control complexity and cost stemming from the rotor energizing current, which modern designs are increasingly addressed through improved cooling strategies and power electronics. While brushed operation is traditionally the most common, modern brushes can last a vehicle's lifetime and wireless power transfer methods are gaining in popularity.

Axial flux motors, also called pancake motors, take advantage of a shorter magnetic flux path that runs parallel to the axis of rotation, a cubic relationship between torque and motor diameter, and a greater magnetic interaction surface area to increase power and torque density along with efficiency [2]. This makes axial flux motors strong contenders for hybrid vehicle range extender and in-wheel drive applications. However, these very high-performance machines generally come with an equally high price tag arising from a combination of air gap control complexity in manufacturing, the use of materials like carbon fiber for structural integrity and lightweighting, and use of rare earth permanent magnets.

These architectures, when combined, enable Torev to develop magnet-free oil-cooled motors anticipated to produce peak torque and power densities of 15 Nm/kg and 3.5 kW/kg, and peak efficiencies upwards of 96% for their 180 kW 800 V flagship motor unit. These motors have an expected envelope of 370 mm OD x 225 mm Length.

This product is TRL 4 and has been tested and validated by 3rd party motor testing firms, with a 15kW sub-scale prototype in operation and the 180 kW units expected to be ready for customer validation testing in the next 12 months.

## 1.2 Applications & Opportunities

Key advantages of this technology include direct control over the rotor field windings, the use of no permanent magnets, and the axial flux architecture. The rotor field is directly controlled, enabling an additional degree of system-level powertrain design freedom, the ability to fully demagnetize the rotor fields, and full motor programmability suitable for software defined vehicle architectures. No permanent magnets means both cost savings and no thermal demagnetization risk, the peak temperature of the motor is instead defined by the insulation class. The axial flux geometry fits naturally into a hybrid vehicle's bell housing and also enables direct drive optionality as these motors generally perform strongly at speeds matched to that of an ICE crankshaft. ●

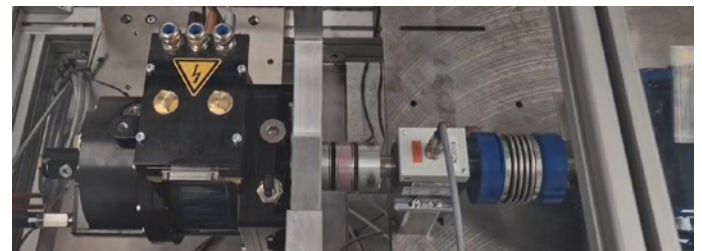

Top: Torev 15kW prototype (black) on test rig

Left: Torev standalone 15kW prototype

## References

- [1] Schaeffler. Magnet-free axle drive EESM. <https://www.schaeffler.de/en/products-and-solutions/e-mobility/magnet-free-axle-drive-eesm>  
 [2] E-Mobility Engineering. (2021, May 17). Power and torque density. <https://www.emobility-engineering.com/challenge-of-power-torque-density>.

# Rethinking Power Conversion for Mobility

Kim App, VP Sales & Marketing, Marel Power

Electrification is redefining passenger vehicles and heavy-duty trucks, placing new demands on efficiency, power density, scalability, and supply resilience. At the center of this shift is the power conversion layer — the link between the power semiconductors and the systems that deliver motion. Marel's architecture rethinks how electrical and thermal paths work together, allowing semiconductors to do more with less. The result is a platform that cuts size and weight by 50% and semiconductor count by a third, while staying flexible across applications and semiconductor suppliers. To be clear, Marel does not manufacture semiconductor die, nor does Marel build full inverter systems. Instead, Marel delivers ultra-compact power stacks that sit between the two, enabling performance levels that conventional architectures cannot achieve.

## Unlocking More from Every Die

Traditional power modules limit performance through high thermal resistance and parasitic inductance. Conventional designs place dielectric material close to the die, restricting heat removal, while inefficient electrical paths introduce overshoot, ringing, and switching losses. Our architecture addresses both by relocating the dielectric closer to the coolant, and double-sided cooling of the die and enabling a more direct thermal path., increasing thermal capacitance and thermal conductivity. The result is  $\sim 0.05$  K/W thermal resistance junction to coolant (8 SiC per switch), and  $\sim 2$  nH parasitic inductance. This enables each semiconductor die to operate closer to its true capability, increasing current per die and reducing the number of die required to achieve a given power level—lowering system cost.

## Compact Scalable Power for Mobility

The architecture is inherently modular, easily scaling from hundreds of kilowatts to megawatt-class systems. For passenger vehicles, this enables smaller, lighter inverter systems. For heavy-duty trucks, it delivers high continuous power in a compact form while reducing cooling system size and complexity. Requiring fewer semiconductors and supporting both IGBT and SiC from multiple suppliers, the system also improves supply resilience and adaptability to support evolving technology roadmaps.

## A New Foundation for Electrification

Marel operates between semiconductor suppliers and system integrators, providing the core power stack that enables next-generation inverters and converters. A simple visual—such as a 1 MW power stack next to a Coke can—makes the value clear: exceptional power density. By rethinking how power is packaged, cooled, and scaled, this approach delivers meaningful system-level advantages in size, weight, performance, and flexibility. The result is not just incremental improvement, but a structural shift in power conversion designed for the next generation of mobility. ●



## Interview

# “Our Future Hybrids are Designed to Fit in All Current BEV Platforms”

In addition to dedicated hybrid transmissions, Horse Powertrain also supplies dedicated combustion engines and complete drive modules. At the 28th CTI Symposium in Berlin last December, we spoke to Ingo Scholten, CTO of Horse Powertrain, about developments in current and future hybrid technology.

Ingo Scholten, CTO, Horse Powertrain

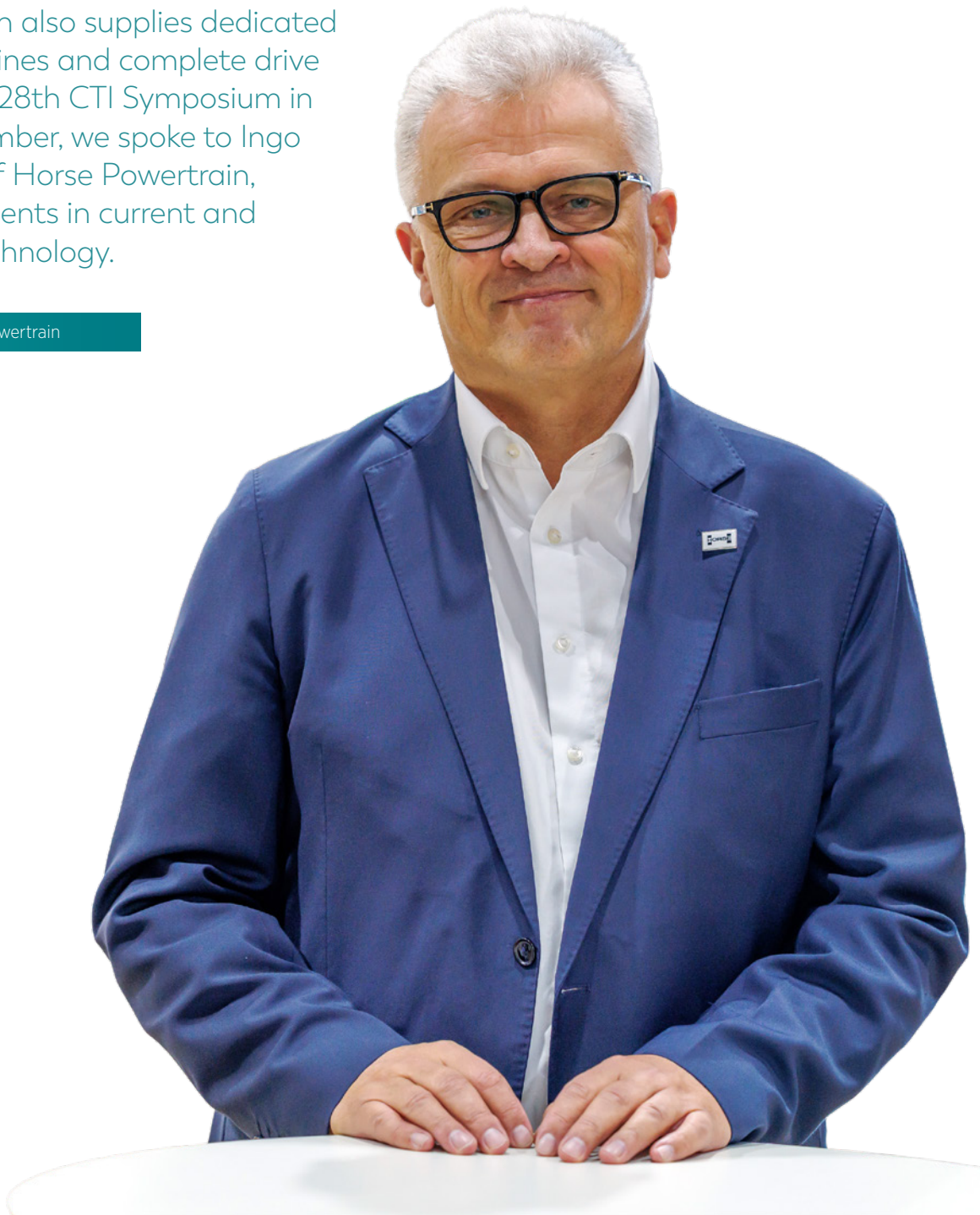

### **Mr. Scholten, Horse Powertrain has a broad portfolio of hybrid drives, but also produces its own dedicated hybrid engines and ICEs. That's unusual for a Tier 1 supplier ...**

It is. There used to be a lot of 'transmission-only' suppliers for manual transmissions, automatics etcetera. But usually, OEMs made their engines and dedicated hybrid transmissions, or DHTs, in-house. Now we offer both – as a system supplier. That makes us quite special to our partners. Instead of just components, we can also offer entire drive systems – plus full integration support, including topics like emissions and homologation.

#### **What are customers asking for?**

Firstly and naturally, we still make drives for Geely and Renault, our parent companies. The Renault E-Tech hybrid, for instance, is now in its third generation. For Mercedes, we supply a 1.5-liter combustion engine for mild hybrids. In China, we're developing our dual-motor DHTs, which now use dual-shaft transmissions instead of planetary gearing in earlier years. And we're talking to other customers in Europe and the US. The demand there for full hybrids is even stronger than in China, but they also want PHEVs. We are discussing range extenders more and more, too. In China, it's mostly long-range PHEVs with a parallel option; they have big traction motors, and drive like EVs. In Europe, drivers still use manual transmissions so multi speed system are accepted even in combination with electrification. But in China, multi-speed transmissions can be a problem because customers there expect an EV driving experience.

#### **Dual-motor hybrid drives are gaining ground. When do you use serial-only, and when is serial-parallel better?**

For maximum efficiency, including on highways and rural roads, you'd normally use serial-parallel – mostly P1 and P3. A serial-only drive would cost you 4-5% in efficiency. Parallel or multi-speed transmissions are better for higher tractive force requirements. P2 still has its place for small vehicles in segments A or B. And if you already have an all-wheel-drive system with an electric rear axle, P2 is fine there too; you don't really need a hybrid drive with two electric motors in the front then. P2 can also work when OEMs design vehicles as 'BEV native' or 'BEV first', respectively. Space is limited, so a P2 with a single electric motor can be practical when a market needs a hybrid variant of the BEV.



### Looking at P1/P3 hybrids, we're seeing solutions with a single fixed gear, and solutions with two, three, or four gears. What do you think will prevail?

When markets want cars that 'drive like a BEV', it makes sense to have fewer gears. Often, just one is enough. For high towing capacity, you can use multiple gears to modulate tractive force. When customers ask us for advice, we often recommend either a large traction motor with one fixed gear or a powertrain with four gears and a smaller traction motor. As I mentioned, Renault has a successful solution that's now in its third generation.

### Many OEMs still need two vehicle platforms; others are moving to 'BEV first' and using a BEV platform for hybrids, too. What's your approach?

That's currently one of our main topics, as I showed in my presentation here at CTI. Some vehicles still use traditional hybrid architectures, which require certain compromises; others use BEV-only architectures. A hybrid drive with one or two electric motors requires more space than an ICE-only drive, whereas a BEV drive requires much less. So, if you optimize a vehicle's front end for BEV, the installation space is shorter and, above all, narrower. The subframe mountings are configured differently, the drive shafts sometimes go in front of the axle. And then a traditional hybrid drive won't fit. You need a hybrid drive design that fits within a BEV vehicle architecture without requiring OEMs to compromise their BEV optimization.

### Which of your products meet that requirement?

Firstly, there's our highly compact HORSE G10 for range extenders. It has a two-cylinder boxer engine with a compact pushrod design and a generator mounted directly on the crankshaft. Then we developed the HORSE C15, a range extender as well. This can be installed either vertically or horizontally. And then we have the Future Hybrid System, which is available in P2 or P1/P3. According to our research, it fits most of the dedicated BEV platforms currently available. So, if European customers with a BEV-first approach want a hybrid derivative for their platform, they can use these powertrains while still meeting all the BEV crash-test requirements.

### You also offer dedicated hybrid combustion engines. What are their thermal efficiencies, and how much more is possible?

We are in production with over 44 percent brake thermal efficiency. And those are figures from engineering, not marketing. We're aiming for 49-50 percent. But to get there, we need to implement a few more technologies – for instance, lean combustion. We also then need to design exhaust systems that won't significantly increase overall system costs. On the other hand, ICE dynamics are lower in serial operation, so that simplifies exhaust after-treatment to a certain extent. For tomorrow's

lean-burn engines, the key is to keep lambda above 2.2 as much as possible so after-treatment doesn't get too complex.

### How do you rate the potential of synthetic fuels in terms of lower CO<sub>2</sub> emissions?

Nobody expects all the markets to switch to synthetic fuels in the short term. But it could well be a gradual process. In five years' time, maybe we could add five percent of synthetic fuels, then later fifteen percent, or twenty. The really good thing is that you can reduce CO<sub>2</sub> across your whole existing fleet. Methanol is another field in which Geely is working. They started selling methanol engines in 2013. Originally, these were 100 percent methanol, designed for taxi fleets in regions where methanol was basically a by-product of coal mining. But now they're working with bio-

methanol and trying to create a circular economy there. At last year's Vienna Motor Symposium, Geely presented onboard CO<sub>2</sub> capture for trucks, for example. Some innovations are just getting started, but we're already seeing potential here and there.

### The EU Commission has just reopened the window slightly for combustion engines after 2035. What do political decisions like this mean for Horse Powertrain?

None of our products is specifically designed for Europe. Our product strategy is very broad, with products we use in the European market, Brazil, India, and elsewhere. So, in terms of capacities and defining technical requirements, decisions about the time after 2035 don't affect us that much. As a globally operating company, we offer solutions that can meet the requirements of various and changing markets. ●



# Thermal Analysis of Axial-Flux In-Wheel Motors

Investigating e-motor thermals as a result of free-surface flow cooling strategies has long been a complex, laborious effort. We demonstrate a novel simulation method – Mesh-Particle Multiphysics (MPX) – which can provide high-fidelity insights from a single simulation run.

Johannes Becker, Dive CAE

Liam Pek, Dive CAE

Automotive drivetrain electrification presents major challenges to engineering teams, as performance, thermal, weight, and packaging requirements drive the need for increasingly efficient and power-dense designs. At the same time, global supply chain volatility drives the need for high-performance motors that do not rely on rare-earth magnets to enable domestic manufacturing and strengthen industrial resilience.

The primary objectives of drivetrain prototyping are to validate performance, efficiency, durability, and system integration before moving to production. Prototypes for e-motors undergo thorough load testing on test rigs and in demonstrator vehicles to confirm structural and thermal stability under expected real-world and extreme conditions. Insufficient cooling and lubrication leading to prototype failure results in costly iterative rework or even changes to the underlying system architecture, significantly impacting time-to-market.

While virtual testing of lubrication and cooling performance via simulation has been industry standard for years, it is often done in isolated domains, as workflows to combine particle-based simulations used for oil flow analysis and structural thermal simulations often involving multiple solvers and laborious processing steps that require deep numerical expertise. A novel solution to this problem, Mesh-Particle Multiphysics (MPX), enables single-run analyses of free-surface flow lubrication and cooling strategies including full conjugate heat transfer (CHT) through structural elements with timescale coupling. Leveraging the strengths of Smoothed-Particle Hydrodynamics (SPH) for the fluid dynamics of jet, spray, or sump cooling, and the Finite Element Method (FEM) for heat propagation through structures in one unified solver architecture reduces complexity and can reduce time-to-result in e-motor studies from weeks to hours.

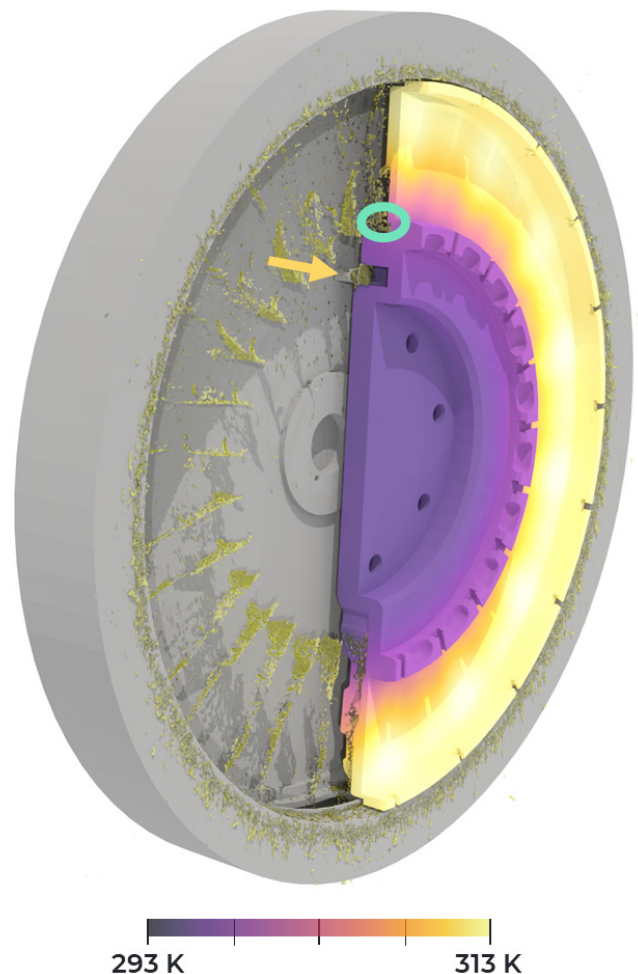

Simulation results visualizing free surface flow of the oil jet (injection nozzle indicated by the yellow arrow) on the left side and heat distribution in the rotor on the right side, resulting from one single MPX simulation. The green circle marks the location of an infrared sensor.

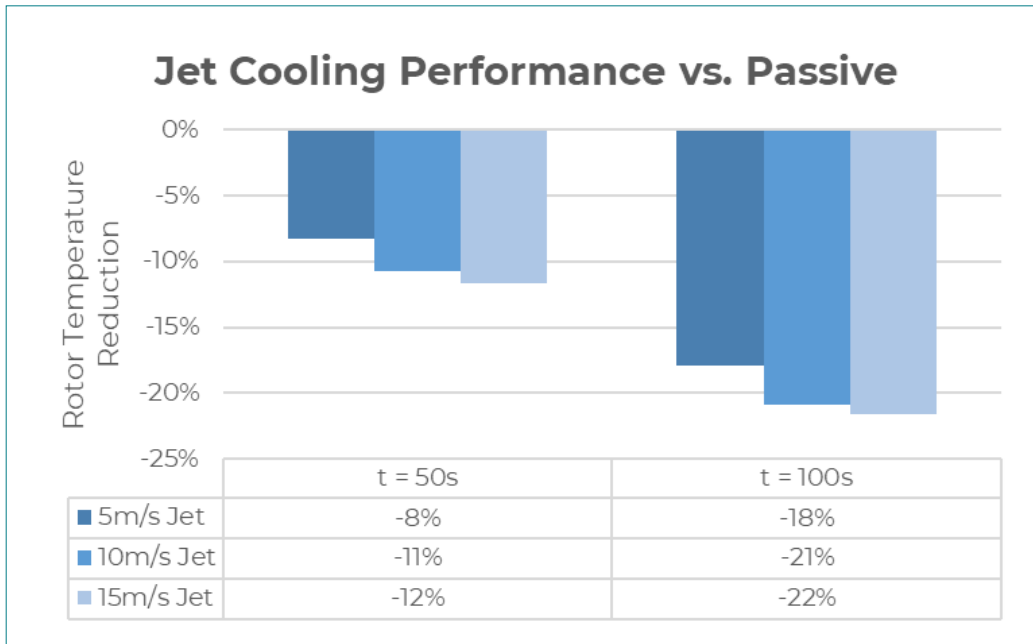

The ORBIS ELECTRIC HaloDrive is an axial-flux electric motor architecture with a wide range of applications across industries, including as an in-wheel motor for passenger EV or commercial vehicle propulsion. Depending on the intended application, it supports different cooling strategies optimized for the expected load cycles, operational environment, and TCO.

Using Dive’s MPX, we investigate thermal performance of rotor cooling, comparing a passively cooled rotor as a baseline case with multiple intensities of active jet cooling, axially applied to the rotor. Jet cooling is confirmed to reduce rotor temperature at the position of a radial infrared sensor (see green circle) by up to 22% after 100 seconds of runtime at 1,500 rpm. While the 5m/s jet configuration reaches steady-state temperatures after about 70 seconds of runtime, both 10 and 15m/s jet configurations stabilize around 30 seconds into the test, with diminishing returns of going beyond 10m/s.

Importantly, results for this study were obtained in a single afternoon – requiring less than one hour of simulation pre-processing and four to five hours (depending on flow rate) of simulation time. Executing thermal studies on complex free-surface flow phenomena enables simulation-driven design that produces advanced cooling strategies which are well-validated and understood before going into a physical prototype. ●

**References**

- ▶ HaloDrive model provided by ORBIS ELECTRIC. [www.orbiselectric.com/halodrive](http://www.orbiselectric.com/halodrive)
- ▶ Mesh-Particle Multiphysics (MPM). [www.divecae.com/technology](http://www.divecae.com/technology)

# We Need to Talk About the Grounding Ring

Goeff Lewis, Technical Director, Duvelco

OEMs love SiC and GaN [1]; higher switching speeds lead to more efficient motors, which in turn mean greater range or lighter, less expensive batteries for the same BEV range.

Higher switching speeds,  $\frac{dV}{dt}$ , can mean increased displacement current coupled onto the motor shaft [2].

For a given common-mode voltage (CMV) amplitude, this causes the floating shaft voltage to reach its limit more quickly. Oil films on the bearing races can break down at around 20 to 50 volts, which in turn can lead to bearing damage through electrical erosion (EDM) and related pitting. Higher-speed, higher-frequency multipole motors mean the number of possible EDM events increases broadly in proportion to the voltage excitation frequency, hastening possible bearing failure.

One widely adopted solution is to fit a shaft grounding ring, which effectively clamps the floating shaft voltage to near zero — typically within a few volts in practice.

## Why don't OEMs love this solution?

- › **An additional component** with associated cost, complexity, and assembly considerations.
- › **Axial packaging space requirement**, which can be challenging in highly integrated e-axle designs.
- › **Requirement for a dry operating environment** (i.e. separation from the lubrication system), which may necessitate additional sealing and space.
- › **A wear component** that may not reliably meet the -15-year design life expected of BEV drivetrains.
- › **Potential source of NVH (Noise, Vibration and Harshness)**, particularly noticeable in inherently quiet electric vehicles.
- › **Most critically, a hidden degradation mechanism** can be difficult to detect and may lead to non-graceful bearing failure, potentially immobilising the vehicle.

## Ducoya Encapsulated Bearings

- Low friction and high wear resistance in demanding PV conditions of up to 14MPa.m/s unlubricated
- Temperature range of -273°C up to 400°C in a favourable chemical environment.
- PFAS Free, non-flammable in air, as can be confirmed by UL 94 V-0 and 5VA testing.

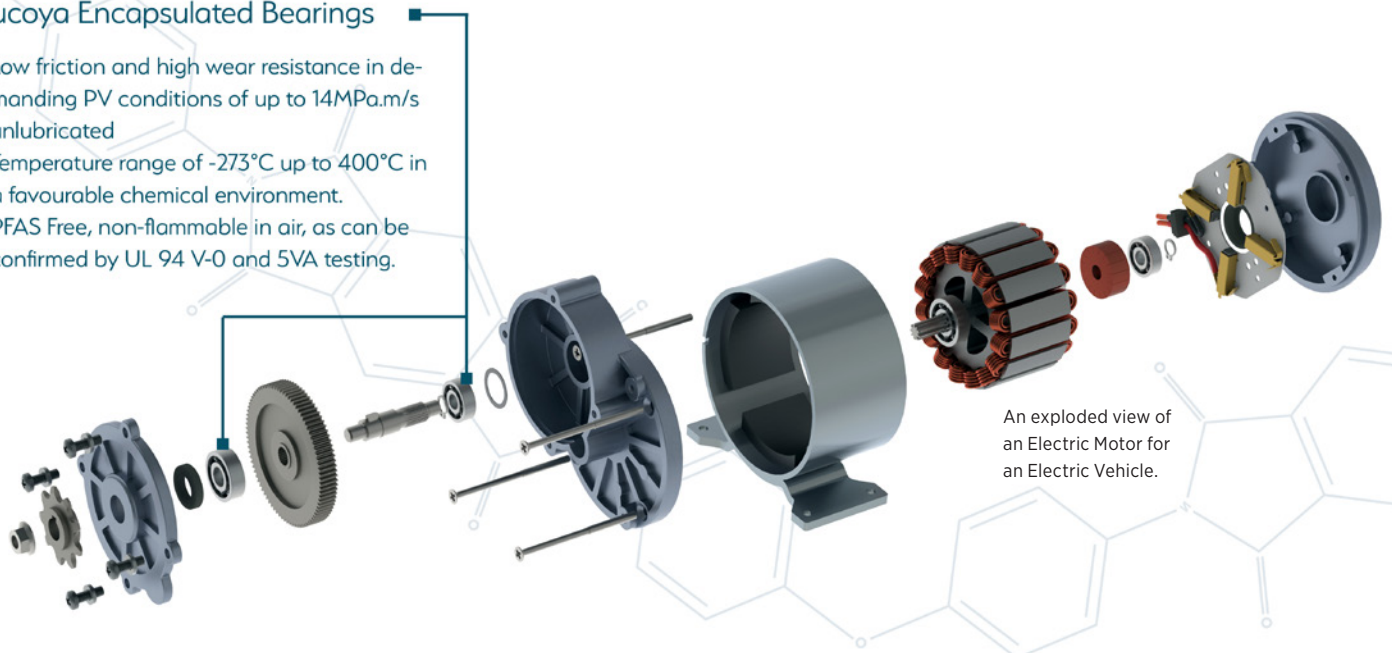

An exploded view of an Electric Motor for an Electric Vehicle.

Engineers and product managers have therefore sought to design out the risk of EDM entirely - the ideal solution. However, despite the use of advanced filters and common-mode chokes, this has not yet been achieved without compromising the efficiency gains offered by SiC- and GaN-based inverters.

A commonly adopted mitigation strategy is the use of electrically insulated bearings. These may take the form of bearings with ceramic insulating coatings or hybrid bearings with ceramic rolling elements.

Such bearings can be relatively expensive and, to some extent, more fragile. In addition, thin ceramic coatings with a moderate dielectric constant can still support capacitive coupling, allowing displacement currents to flow and reducing the overall impedance at high frequencies.

A dimensionally stable, creep-resistant polymer insulator with a low dielectric constant (e.g.  $\sim 2.7$  at 1 MHz and 150 °C) could enhance the robustness of such mitigation strategies.

Research from Leibniz Universität Hannover (IMKT) has shown that polyimide coatings can exhibit higher electrical impedance than conventional ceramic coatings, approaching that of hybrid bearings while providing improved robustness [3].

Building on this work, Ducoya — a highly crystalline, PFAS-free PMDA-ODA polyimide from Duvelco — offers excellent flow characteristics, enabling high-precision moulding of thinner-walled sections. Its relatively low dielectric constant also helps reduce parasitic capacitance and associated displacement currents. Together, these attributes enable reduced material usage and improved dimensional control, providing an economically attractive route to enhance the robustness of grounding strategies and mitigate EDM-related bearing damage.

Duvelco Ducoya also exhibits high compressive and tensile strength and toughness at elevated temperatures, which may be advantageous across a wider range of applications.

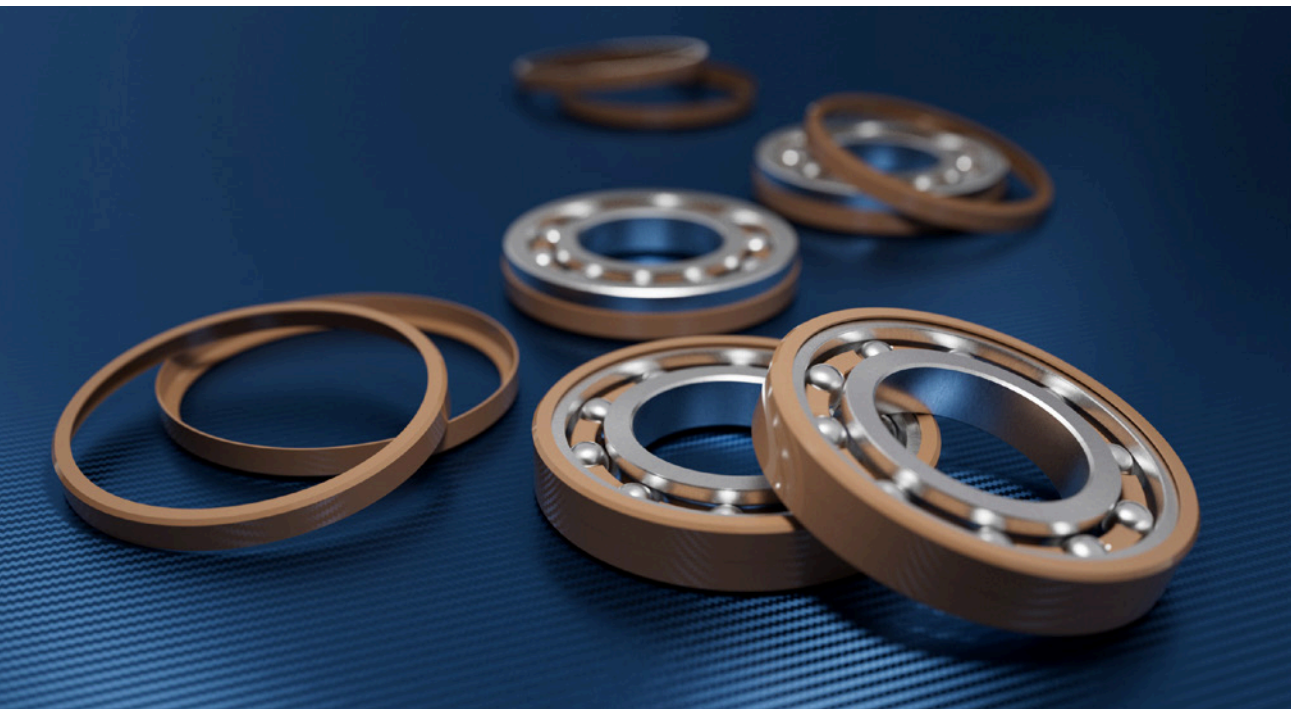

Duvelco Ducoya is available both as a moulding-grade polymer for use with suitable modern precision processing equipment and as finished components for integration by bearing manufacturers or OEMs.



The preliminary data in the graphs below, demonstrates how Ducoya also exhibits high compressive and tensile strength and toughness at elevated temperatures, which may be advantageous across a wider range of applications.

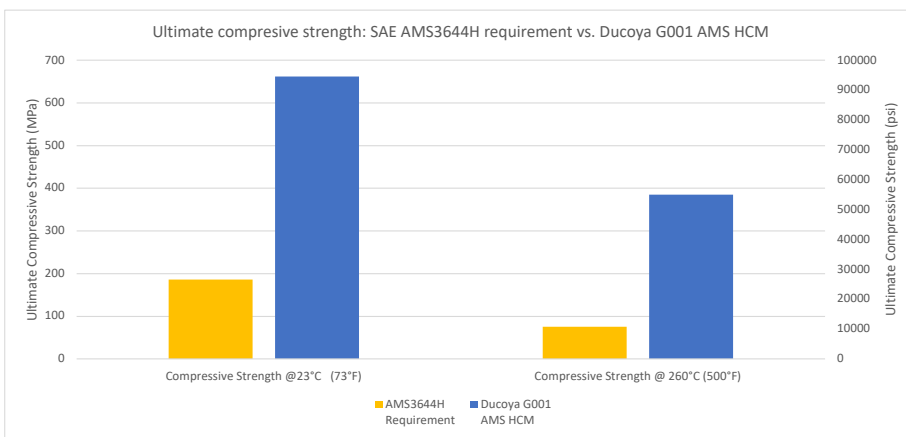
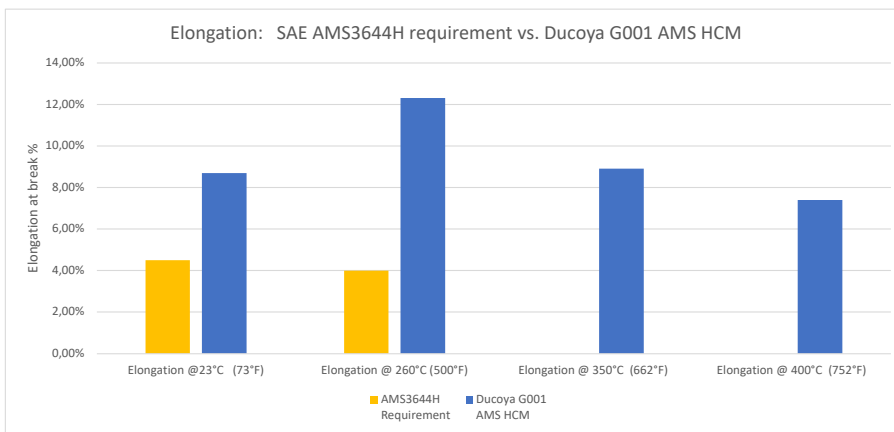
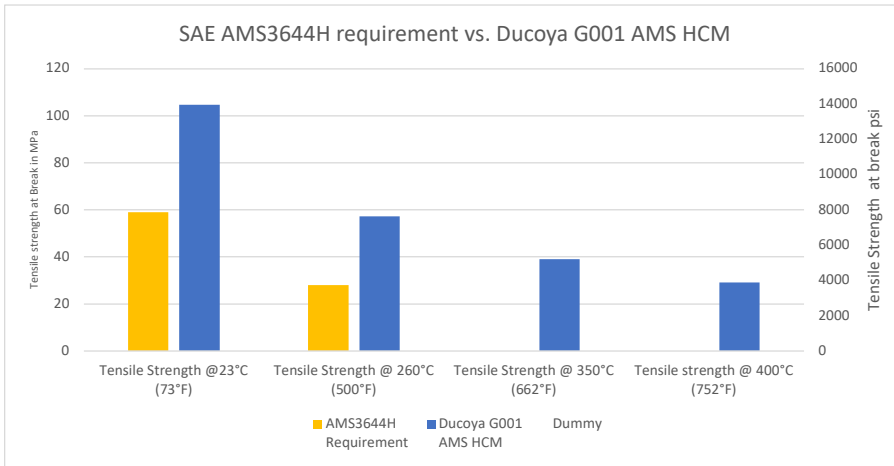

As electrified powertrains continue to evolve, the focus is increasingly shifting from mitigating EDM risk to addressing it at source. Advanced materials such as Ducoya may offer new possibilities for more robust, space-efficient insulation strategies, helping engineers explore alternatives to traditional approaches. The question is: could a material-led solution play a greater role in future drivetrain design? ●

[1] Silicon Carbide and Gallium Nitride.  
 [2]  $I = C \cdot \frac{dV}{dt}$   
 [3] Pauchard, P., Berger, C., and Jackowiak, R., "Effective Solutions for bearing Insulation to prevent electrical corrosion in E-Drive Systems" CTI Magazine, December 2025, pp. 25.

# How AI Redefines Automotive Engineering Workflows

Théophile Allard, CTO and co-founder at Neural Concept

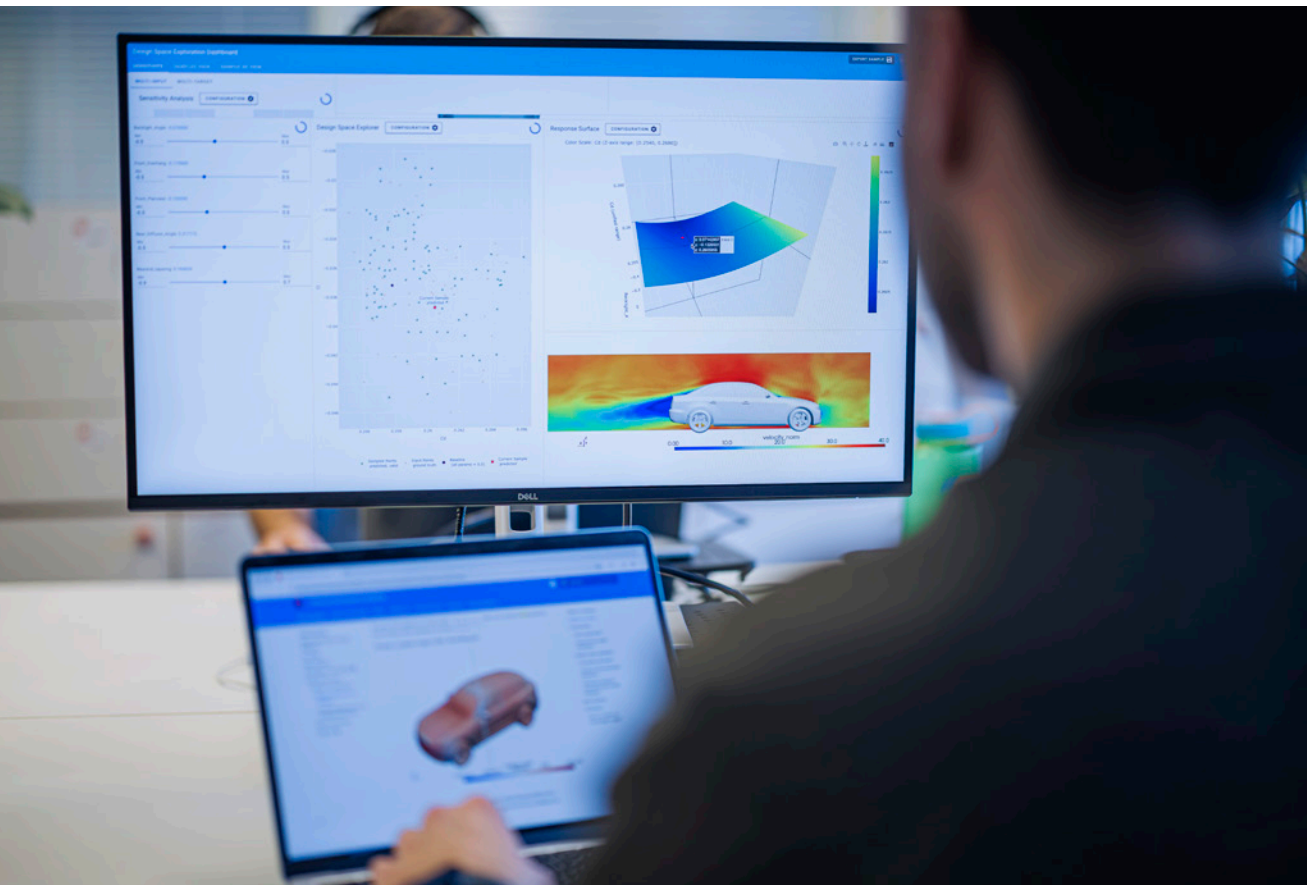

The automotive industry is undergoing a structural shift. Development cycles compress from years to months, regulatory requirements multiply and customer expectations rise. The automotive industry's structural challenges feel more burning than ever : deliver better vehicles, faster, without sacrificing quality or cost.

For decades, the answer was adding more tools and specialists. But engineering organisations are fragmented, iteration loops are long, and system-level insights arrive too late. In perspective, AI looks like the perfect solution that will magically absorb workloads and shrink timelines. In reality, despite heavy investment, most initiatives stall at the pilot stage.

The issue is workflow fit, not AI capability. What is needed is a different engineering playbook, one built around how AI-native development actually works.

## The fragmentation problem

Modern vehicle development involves hundreds of specialists across aerodynamics, thermal management, crashworthiness, NVH, and manufacturing, each operating with separate tools and timelines.

This workflow is deeply sequential: designers create geometry, analysts spend weeks on simulations, results return, changes are requested, the loop repeats. By the time conflicts surface, design freedom has evaporated. Today, AI can generate and evaluate thousands of design variants per day across multiple physics domains. The constraint is the old workflow, not ready to leverage these new technology capabilities.

## From iteration to exploration

The shift happens when teams move from design iteration to design space exploration. Traditionally, engineers work on one design at a time, modifying CAD, running simulations, and interpreting results.

In AI-native workflows, engineers define a design space with rules, constraints, and performance targets. AI populates that space with thousands of variants. Engineers navigate possibilities, select promising designs, and refine constraints. This fundamentally changes how engineering knowledge is captured, shared and applied.

## The intelligence layer

For this to scale, AI must embed in tools that engineers already use, not exist in isolated environments. In practice, AI functions as an intelligence layer connecting to CAD, CAE, and PLM systems through APIs. Engineers work in familiar interfaces but gain AI-powered features: automated geometry generation, real-time performance feedback and cross-discipline constraint propagation.

AI-based surrogate models trained on historical simulation data predict aerodynamic drag, thermal performance, or structural behavior with near-CFD/FEA accuracy at a fraction of computational cost. Engineers see design changes consequences in real time, early exploration happens where iteration is cheap and fast, and promising candidates get validated with high-fidelity tools only when needed.

At scale, this approach collapses development timelines, reduces late-stage redesigns, and shifts critical decisions to phases where design freedom remains high.

## The path forward

For organizations ready to make this shift, the first step is identifying workflows where fragmentation causes the most friction and faster exploration would deliver clear value. Aerodynamics and thermal management are common entry points: physics are well understood, simulation data is abundant, and geometry changes have measurable impact.

But success requires more than deploying technology. Engineers need training, infrastructure must support AI workloads at scale, and organizations must accept that this transition will not happen overnight. Those who get it right will make designers more productive, decisions more informed, and better products. ●

# Start-Ups at CTI SYMPOSIUM USA 2026

The CTI SYMPOSIUM is committed to supporting the transformation within the industry. Following the outstanding response to the launch of our Start-up Area in Novi in 2025, we are excited to bring “Start-ups @ CTI” back for its second edition in 2026 – now with an even larger number of pioneering young companies.

At CTI USA 2026 you'll meet founders in person, explore their innovative products, and learn more about their solutions with the potential for succeeding in today's challenging and fast-changing automotive environment.

We are delighted to welcome an expanded line-up of highly promising start-ups to CTI in Novi 2026!



## **Acerta**

Acerta Analytics develops domain-specific AI for discrete manufacturing to improve production quality and reduce the cost of poor quality. Its platform, LinePulse, provides advanced quality manufacturing analytics that analyze production and test data to detect abnormal trends, identify root causes of failures, and enable faster problem resolution. Built for complex, high-volume manufacturing environments, LinePulse combines multivariate analytics, real-time SPC, and traceability to uncover relationships across machines, processes, and plants. Manufacturers use LinePulse to move from reactive quality monitoring to proactive, scalable problem-solving—reducing scrap, rework, and warranty risk while improving operational performance.

[www.acerta.ai](http://www.acerta.ai)



## **Dive Engineering Software, Inc.**

We empower engineers with particle-based simulation software that takes care of everything. No installation, no hardware – just engineering.

Engineers should focus on delivering great products. Our mission is to get rid of all distractions and limitations within the development process. We are committed to providing the leading cloud and browser-based engineering environment that enables product design teams to set up, compute, analyze, and share design studies hassle-free.

Our Smoothed Particle Hydrodynamics software solution accurately predicts free surface flows, multiphase flows, and moving machinery – enabling virtual drivetrain lubrication and cooling analyses. All you need is a browser.

[www.divecae.com](http://www.divecae.com)



### Duvelco

High-Performance Polymer for the Demands of E-Mobility

Duvelco is a UK-based advanced materials engineering company, pioneering a new generation of high-performance polyimides for demanding engineering environments. At the heart of our offering is the Ducoya® G-Series — a patented polymer developed in-house to deliver exceptional thermal stability, low outgassing, and ultra-low wear. Designed for e-mobility, automotive transmissions, aerospace and semiconductor sectors, our polymer resins and precision-machined components offer lightweight, durable solutions where reliability is critical. From bushings and bearings to seals and insulation, Duvelco supports engineers in tackling complex tribology and cleanliness challenges. With an expanding network of technical partners across Europe, the Americas and Asia-Pacific, we are actively engaging with OEMs and Tier suppliers across the global automotive supply chain.

[www.duvelco.com](http://www.duvelco.com)



### EcoNovaTech

We offer innovative design solutions for transmissions using patented technology to achieve smooth transitions without interruption, replacing synchronous clutch with Geneva mechanism, suitable for high-speed rotation such as EV. We also offer non-circular gear / Geneva wheel technology for IVT.

[www.econovatech.com](http://www.econovatech.com)



### GAMIC

The Global Automotive & Mobility Innovation Challenge (GAMIC) is a 501c3 non-profit based in the Great Lakes region. GAMIC hosts an annual competition for global automotive and mobility innovation. Each year, startups coming from more than 30 countries participate in the competition while developing and refining their innovation proposals. GAMIC's mission is to identify, mentor, and promote global startup innovations targeting the North American mobility market. By offering support and access to industry professionals, investors, and other ecosystem partners, we empower entrepreneurs to accelerate their market penetration. To date, GAMIC Champions have raised more than \$1 billion USD in funding.

[www.gamicevent.org](http://www.gamicevent.org)



### Marel Power Solutions

Marel Power Solutions is a pioneering power electronics company, focused on advancing powertrain systems for electrified mobility. Marel packages power semiconductors densely and cools them aggressively in its patented configurable power-stacks. These power-stacks are central to power converters that connect batteries and electric motors. Marel's technology enables compact, light, scalable power converters, using a third fewer semiconductors. Marel is working with leading automotive clients, providing them prototype units from our North American pilot line. While focused on mobility, Marel's modular architecture is easily adaptable to industrial, aerospace, datacenter, defense, and renewable applications, widening its relevance across the electrification landscape.

[www.marel-power.com](http://www.marel-power.com)



### Neural Concept

Founded in 2019, Neural Concept provides the leading AI-first engineering platform for product development. By embedding AI natively into design and simulation workflows, Neural Concept empowers engineering teams to compress development cycles from months to days, improve product performance across efficiency, safety, and sustainability, and scale AI adoption without costly, years-long integration.

The company drives product development across major industries, including automotive, aerospace, energy, consumer electronics, semiconductors and defense, working with the world's leading global OEMs and component suppliers. Neural Concept is headquartered in Switzerland, with a growing global presence including offices in Munich, New York and the Asia-Pacific region and is backed by global investors, including Goldman Sachs, Forestay Capital and D. E. Shaw Group.

[www.neuralconcept.com](http://www.neuralconcept.com)



### NTF Micro Filtration

NTF Micro Filtration is a leading designer and manufacturer of advanced precision fluid filtration solutions for automotive and industrial markets.

The company specializes high-efficiency suction and pressure side filters for eAxles, transmissions, electric vehicle battery cooling systems, fuel, hydraulic, and engine applications. With in-house engineering, prototyping, testing, and manufacturing capabilities, NTF delivers customized solutions that meet stringent cleanliness and performance standards for OEM and aftermarket customers globally.

[www.ntf-filter.com](http://www.ntf-filter.com)



### Physna

Physna is a 3D data company that enables organizations to unlock the full value of their engineering and design data. Its platform uses advanced geometric search and artificial intelligence to analyze, compare, and manage 3D models with precision. Physna helps manufacturers and engineers improve product development, reduce costs, and streamline supply chains by making complex 3D data searchable and actionable across teams and systems.

[www.physna.com](http://www.physna.com)

**Torev Motors**

Torev develops high performance magnet-free electric motors for automotive and defense vehicles. The company's patented wound rotor axial flux architecture insulates customer supply chains from rare earth metals while offering comparable performance to magnet-based legacy motor alternatives. Torev is funded by the US Army, is venture capital backed, has a functional TRL 4 prototype validated by independent 3rd party tests, and won the 2024 Global Automotive & Mobility Innovation Competition. The company is seeking development and pilot partners for their upcoming 150kW product line.

[www.torevmotors.com](http://www.torevmotors.com)

**Traction Drive**

Traction Drive LLC is a small engineering company working to bring multi-roller traction drive technology to modern electric drive units.

The idea is straightforward: replace the helical gear reducer in a high-speed EV drivetrain with a compact roller cluster that transmits torque through rolling contact — no gear teeth, no gear noise. The underlying science was validated by NASA in the 1970s and 80s. We think the timing is finally right to build it for EVs. Led by Joe Kliewer, a transmission and traction drive engineer with 20+ years in rolling element contact design and 11 issued U.S. patents.

[www.tractiondrive.com](http://www.tractiondrive.com)



# AI Fuels Vehicle and Powertrain Development

Development work in electric motors and drives remains highly innovative, range extenders are finding their place beyond China, too, and artificial intelligence is increasingly conquering cars and powertrain technologies. A review of the 28th CTI Symposium, Automotive Powertrain Systems, Berlin, in December 2025.

Report: Gernot Goppelt, CTI Correspondent

After more than a century, can electric motors develop any further? Yes and no, said **Prof. Malte Jaensch, chair of the CTI Symposium Berlin**, in his opening address. No, because technologies like axial flux machines were indeed invented a long time ago. And yes, because automobile powertrain electrification was now sending fresh development impulses. The ongoing development of various types of **electric motors and drive units** was one of three key topics in Berlin. It featured plenary presentations from Mercedes, Rimac, and Yasa, contributions from young startups, and many of the 77 technical deep-dive lectures, arranged in 13 parallel sessions.

Another major topic was **Artificial Intelligence**, which was discussed in greater depth and breadth than ever before. Themes ranged from AI-based agents or in-car assistants to AI as a tool for improving and streamlining automotive development processes.

Just shortly after the symposium, the EU Commission announced its proposals for the future of ICEs after 2035. Essentially, these require manufacturers to make new car fleets only 90 percent emissions-free rather than 100 percent. This could create opportunities for REEVs (Range-Extended Electric Vehicles) in Europe as well. **REEVs** for passenger and even commercial cars were a third major subject at the symposium.

## REEV as a BEV variant

### In China, for China

**Dr. Tobias Giebel of Volkswagen China Technology Company (VCTC)** kicked off the plenary sessions with his presentation entitled **“Chinese Powertrain System Trends.”** VCTC is a Volkswagen R&D center in Hefei. It opened in 2024 and focuses entirely on a ‘China for China’ approach.



Giebel began by briefly discussing NEVs (New Energy Vehicles), noting that they encompass three drive concepts that are all equally supported: BEV (Battery Electric Vehicle), REEV (Range-Extended Electric Vehicle), and PHEV (Plug-in Hybrid Electric Vehicle). One difference between REEVs and PHEVs is that the former are only serial-drive, whereas PHEVs also permit a direct connection from the ICE to the wheels. Together, the three types of NEVs accounted for 56 percent of the market share in China. Since October 1, 2025, VW has been developing its NEV drive systems entirely on-site at VCTC. In line with the ‘BEV first’ approach, BEVs, REEVs, and PHEVs all share a common vehicle platform. Giebel said the three top criteria for tomorrow’s NEVs were affordable and fast-charging LFP traction batteries, new dedicated hybrid engines (DHEs) with over 40% thermal efficiency, and electric drives with SiC-based, pulse-optimized inverters. Turning to opportunities for REEVs in Europe, Giebel shared two interesting insights. Firstly, gasoline costs 10 times as much as electricity in China, so REEV drivers there use the battery pack whenever possible. Secondly, the company’s BEV-first approach saves on vehicle development costs by eliminating the need for two separate vehicle platforms.

**BEV-Native hybrids**

**Horse Powertrain** is a Geely–Renault collaboration focused on developing modern hybrid powertrains. **Ingo Scholten, CTO of Horse Powertrain**, spoke about “Hybrid Future – Many Paths to Net Zero”. Scholten sees hybrids not as competitors to BEVs, but as a complementary technology that accelerates electrification. He also noted that a BEV battery requires 20 times as many critical raw materials as a full-hybrid battery. In many regions, BEV infrastructures would remain sparse for the foreseeable future. Hence, many consumers were opting for full hybrids – or, increasingly, for range extenders. Scholten also favors a ‘BEV-native’ development approach, but said this also involved different package requirements. This was something Horse Powertrain factored into its hybrid powertrains. For example, a BEV engine compartment is 40% narrower and shorter than that of an ICE-powered car. The upside is

more space for other subsystems or for a more effective crumple zone. But hybrid powertrains definitely had to be smaller to fit into a native BEV. Scholten briefly described the product portfolio, which currently includes several series-parallel DHTs and range-extender (REX) powertrains. The G10, for example, has a flat two-cylinder boxer engine; the C15 has a horizontally mounted four-cylinder unit, and the Future Hybrid comes in two versions: P2 and P1/P3. All these products are designed for the confined space of a native BEV.

**Diversity resolves uncertainty**

Unlike VW or Horse, **Toyota** still backs power-split hybrids, but is also investing in BEV and hydrogen. This is because energy mixes vary widely from country to country. In his presentation “**Toyota’s Multi Pathway Approach Towards Carbon Neutral Powertrains**”, **Timothy D’Herde** cited two examples: In Norway, BEVs have a market share of over 90 percent; in Greece, BEVs, HEVs, and PHEVs together account for just 25 percent. In Greece, he noted, 75 percent of hybrids were Toyota and Lexus models. Toyota’s hybrid system is now in its fifth generation. Over time, the drive motor speed has increased from 5,600 to 17,000 rpm, and the entire system has become significantly smaller. For the third generation, Toyota introduced a dual-axis system with a spur-gear reduction stage to replace the coaxial chain design. D’Herde said Toyota was currently developing a new, naturally aspirated four-cylinder engine for hybrid powertrains. This aimed for 43.5% efficiency, compared to the current version’s 41%. The speaker sees strong potential for CO<sub>2</sub>-



Timothy D’Herde, xxx xxx xxx xxx xxx



Dr. Tobias Giebel, Volkswagen China Technology Company



Ingo Scholten, CTO, Horse Powertrain

neutral biofuels in Europe, and said Toyota was also pursuing hydrogen for fuel cells and combustion engines. According to the „1:6:90 rule“ he shared for ‘smart’ resource utilization, one electric car requires the same amount of lithium for its battery as six plug-in hybrids or 90 full hybrids. D’Herde closed by saying that while tomorrow’s powertrain mix was unclear, „diversity is the solution to uncertainty“ – hence Toyota’s multi-pathway approach.

### REEV for Commercial Vehicles too

In his presentation „**Quo vadis propulsion in a sustainable world?**“ **Dr. Norbert Alt, COO of FEV**, also spoke in favor of REEVs – not just for cars but also for commercial vehicles. A key assumption was that by 2035, e-fuels would not be available in anywhere near the amounts needed to make a significant contribution to reducing CO<sub>2</sub>. Hence, FEV had calculated the lifecycle emissions of various drive concepts – with interesting results. For passenger cars, REEVs with an electric range of 200 km and using E10 fuel came close to the lifecycle emissions of pure BEVs. FEV ran their calculations for both 2025 and 2035. For 2035, a higher share of renewable energy was assumed for battery and vehicle production. As an example, Alt said that in 2023 the Global Warming Potential (GWP) of an REEV was 26 tCO<sub>2</sub>eq, compared to 18 tCO<sub>2</sub>eq for a BEV with an NMC battery and a range of 600 km. A REEV using e-fuel would have a GWP of 19 tCO<sub>2</sub>eq, putting it almost on par with a BEV. Alt made it very clear that he believes in BEV’s long-term prospects. But he also favors sensible transitional technologies, and pointed out that some regions will not have complete charging infrastructures for a long while yet. Alt also sees potential for BEV commercial vehicles, saying distances of 350–550 km are easily manageable. However, REEV could make sense for longer hauls in regions with infrastructure issues. Depending on the driving profile, GWP could be reduced by 26–82% compared to a diesel vehicle. For passenger cars and commercial vehicles alike, Alt favors a ‘hybrid BEV’, meaning REEVs that share a common platform with BEVs.

### Infrastructure Matters

Commercial vehicle electrification was also the theme of the panel discussion **“EV Charging: Joining the Last Missing Dots of Electric Mobility”**. Moderated by Martin Seiwert from the magazine *Wirtschaftswoche*, the panel comprised Simon C. Brück, DSLV (German Association Freight Forwarding and Logistics); Florian Hacker, Öko-Institut; Johannes Pallasch, Now GmbH, and Dr. Stefanie Wolff, VDA. The discussion lasted almost an hour; here are some key points.

Commercial battery electric vehicles (BEVs) are already here, so availability is not an issue. The real obstacle on the road to electrification is charging at public charging stations, which remain too expensive for a viable TCO (total cost of ownership). Infrastructure expert Pallasch called for fresh ideas on electricity billing, specifically across different providers. As Dr. Wolff from the VDA pointed out, most logistics companies are located outside of cities. Hence, businesses needed to discuss grid connections – i.e., better integration of charging infrastructure with other companies. Logistics expert Brück focused on TCO, saying we needed cheaper electricity and a charging infrastructure for long-haul routes because “our business doesn’t stop at the border”. This was precisely why we also need resilience and, hence, an open-minded approach to technology. In reality, he said, it’s not about the drive technology – it’s

about energy availability. On the subject of Chinese competition, Brück said China would first need to establish a maintenance network comparable to those of European truck manufacturers. Hacker, who represents the Öko-Institut (Institute for Applied Ecology), is a staunch pro-BEV optimist. He said people enjoyed driving commercial BEVs and felt more comfortable in them. He could not understand why the German government was working to dilute the phase-out timeline for ICEs, saying this “sent the wrong signal”.

Naturally, this is just a condensed version of the discussion. But together with Norbert Alt’s line of argumentation (see above), perhaps we can sum up as follows: For an acceptable TCO, electricity prices must come down. In remote regions, charging infrastructure issues will persist. Range extenders could be useful even for long-distance travel. Electricity providers need to cooperate better. And unlike fuel availability, energy availability is anything but transparent. In a nutshell: However desirable NEVs in the form of battery electric vehicles may be for long-distance travel, there are still many challenges to overcome.

### Decarbonization in Avionics

The electrification requirements for aircraft are a matter entirely different. In a joint presentation entitled **“The Path to Climate Neutrality in Aviation”**, **Prof. Klaus Höschler from the Brandenburg University of Technology Cottbus** and **Prof. Lars Enghardt from the DLR Institute of Electrified Aero Engines in Cottbus** offered a glimpse of a world beyond the automotive industry. While the potential for reducing CO<sub>2</sub> in avionics was similar to that in automobiles, they said, the challenges involved were far bigger than in heavy commercial vehicles. For fuel cells, these included large tanks, high volume and weight, and low energy density. In combustion engines, hydrogen also raises concerns about NOX emissions and contrails. Nobody knew when e-fuels would be available in sufficient quantities. The main challenges for battery-electric aircraft propulsion were battery weight and lifespan. That said, battery-electric propulsion would be feasible for small aircraft by 2030, and hybrid propulsion with fuel cells by 2035. Hybrid propulsion systems for 100-seater passenger aircraft could enter production by 2040, followed by a more powerful generation of pure-fuel-cell propulsion systems. Large long-haul aircraft would likely still need turbofan engines until at least 2050, albeit technically improved and more efficient.

### New Electric Drivetrains and e-Motors

#### Mercedes’ Next-Generation Electric AWD

Back in the automotive world, **Daniel Hopp**, senior R&D manager for electric powertrain at **Mercedes-Benz**, gave a presentation titled **“Insights into the GLC electric drivetrain”**. Under the motto ‘Efficiency is the new currency’, he presented the new GLC’s drive system. Adopted from the Vision EQXX concept vehicle, its standout feature is the EDU (Electric Drive Unit) design on both the front and rear axles. The rear-mounted PSM primary drive has a two-speed transmission, while the front-mounted PSM secondary drive has a disconnect unit. With ratios of 5:1 and 11:1, the two-speed primary drive offers double benefits: it enables stronger acceleration and shifts the sweet spot to higher vehicle speeds. When cruising, the secondary drive is normally decoupled via a dog clutch, virtually without losses. This allows the primary drive’s second gear, optimized for efficiency, to be used to its maximum advan-



Daniel Hopp, senior R&D manager for electric powertrain, Mercedes-Benz



Jörg Miska,  
CEO, YASA



Vardaan Bhatia, Head of Powertrain Product Management,  
Rimac

tage. The secondary drive has only a boost function. The GLC has a peak power rating of 360 kW. Maximum charging power is 330 kW, and energy consumption is between 14.9 and 18.9 kWh (WLTC). The company plans to use the drive components in other models too.

### Small and Performant Axial Flux Motors

**YASA** is a spin-off from the University of Oxford that became a Mercedes-Benz subsidiary in 2021. **CEO Jörg Miska** spoke on “**Axial Flux Motors: Superior Performance for EVs and Hybrids**”. He began by explaining how axial flux technology works. In conventional radial flux motors (RFM), he said, the magnetic flux runs radially between the rotor and stator; in axial flux motors (AFM), it runs along the rotor’s axis. This design was much flatter and, in the YASA version, offered three times more torque density (20 vs. 7 Nm/kg), twice the power density, and achieved 95% efficiency thanks to a shorter magnetic path. Compared to RFM, AFM requires just one-third as much iron, he said, half as much copper, and a similar amount of magnet material. While the magnet material was more expensive (grain-oriented electric steel), it enabled 5% more power and approximately 9% lower losses in the WLTC. A polymer stator housing further reduced the need for active material. The lower thermal mass made it harder to achieve high peak power, but YASA compensated via measures such as an oil-cooled copper winding and a real-time thermal model. Miska sees advantages for YASA’s Axial Flux Motors in space-constrained applications such as P2 hybrids or twin-motor P4 hybrids for AWD solutions with precise torque vectoring. They could also benefit BEVs, for example, in wheel hub motors. The next-

generation YASA motors are projected to deliver 750 kW of peak power and will weigh just 12.7 kg.

### Rimac Expands Its Powertrain Portfolio

Founded in Croatia in 2009, **Rimac** first became known for hypercars, most recently in collaboration with Bugatti. In his presentation, “**Accessible Performance: How Rimac is Scaling High-Performance E-axes for Next Generation of EVs**”, **Vardaan Bhatia**, Head of Powertrain Product Management, showed how, via its Rimac Technology division, the company is now also positioning itself as a developer and Tier 1 supplier of battery systems, vehicle controls, and e-axes. The current portfolio consists of single- and dual-inverters, two types of electric motors and transmissions each, dual-motor drives, and the Sinteg drive for plug-in hybrids, available in two variants. The goal is a configurable, scalable, high-performance drive that offers best-in-class power and torque density. Rimac is also focusing on an ‘X-in-1 Inverter’, meaning an inverter with proprietary software that integrates all functions onto a single board. As an example, Bhatia showcased Rimac’s current SC1 e-drive platform. This has a power density of 8 kW/kg and a torque density of 90 Nm/kg. It costs less than €8/kW and has an annual production of <10,000 units. In the next step, Rimac aims to get costs below €7/kW and production up to 25,000 units. For the following generation, the targets are 10 kW/kg, 100 Nm/kg, costs of under €5/kW, and production volumes of up to 50,000 units. As of 2027, Rimac plans to transcend the hypercar segment and also equip cars, off-roaders, and commercial vehicles, as well as ‘new mobility segments’.



Dr. Nikolai Ardey, Executive Director Group Innovation, Volkswagen AG

## AI in Cars is Gaining Momentum

### Brain on Wheels

The third major topic at the 28th CTI Symposium was artificial intelligence, which is increasingly featured in cars and in development and business processes.

**Dr. Nikolai Ardey**, Executive Director Group Innovation at **Volkswagen AG**, titled his presentation **“Smartphone on Wheels? Robot on Wheels? BRAIN ON WHEELS! ... to Come From an AI Driven Enterprise”**. He began by listing the levels of AI hierarchy. From bottom to top, these are Machine Learning, Deep Learning, Generative AI, and Agentic AI. AI Agents acted autonomously and with a clear objective. While many people today associate Gen AI with Large Language Models (LLMs), Ardey spoke of a ‘multimodal AI’ that can process any combination of text, images, videos, music, etc., to create a multi-agent system rather than a single agent. He said AI would change virtually everything in cars, “except for the fundamental laws of physics”. Today’s ‘traditional AI models’ were largely perception-oriented. Increasingly, prediction and planning would be added to the mix. A further step would be to implement end-to-end training for all AI modules – a process handled entirely by AI from start to finish. In autonomous driving, more and more information would be drawn from LLMs, VLAs (Vision-Language-Action), and WMs (World Models) – essentially creating a miniaturized world within the AI. The result would be a ‘Large Model Incorporated’. As an example, Ardey described a situation in which a vehicle must react to a complex, dangerous situation. Today, a system can recognize the scenario, but only humans can make meaningful decisions. Ardey used the analogy of vari-

ous interconnected ‘human brain agents’. Another development within the car itself is the ‘Personal Butler’, which already exists in part. In R&D, AI would help to mitigate pain points along the AI model. The speaker cited automated ticketing systems and visual AI agents for function testing as examples. In production, AI could streamline the coordination of multi-robot systems. In sales, it could optimize both benchmarking and pricing. Looking ahead, the entire value chain could benefit from a ‘Large Industry Model.’

With a dedicated session on **“Artificial Intelligence in Powertrains”**, AI played a role in the Deep Dive Sessions in Berlin as well. For the first time, there were also two full-day pre-workshops on the day before the symposium, both of which were in great demand. The first workshop was entitled **„AI Fundamentals & Best Practices in Powertrain and Development”**, while the second examined a very different issue: **„Mobility meets Defence”** – a topic the auto industry is now actively exploring.

### Resilience Needs Innovation and Diversity

All these topics – innovations in electrified powertrains, range extenders, and AI – have one thing in common: Innovation is progressing rapidly. Electric drives still have significant potential for development, at both the component and system levels. REEVs are sometimes accused of clinging to the past, but they can help power decarbonization alongside purely electric powertrains. They can also help combustion engines to become more efficient. It’s becoming increasingly clear that a degree of diversity in the way we use resources can strengthen our economic resilience.

Industry insiders agree that automotive development calls for a holistic systems approach in which components are part of an ‘intelligent’ system. The dizzying growth of AI is accelerating this development further still. The boundaries between vehicles, their utility value as living spaces, and their integration into the environment will become even more blurred. In the field of generative AI, some observers are wondering whether a bubble might be forming. Others say it’s just the usual cycle of hype, downturn, then ongoing development. Either way, it seems plausible that AI, in cars and throughout their whole life cycle, is more than just hype. In fact, it is probably essential for enabling technologies such as automated driving to break through.

The next CTI Symposium takes place on May 19 and 20 in Novi, Michigan. While the focus topics will be similar, ICEs and hybrids may be even more important in the US than they are in Europe. For the first time, chassis and electrified powertrain integration will feature in the symposium program. This reflects the way electric drives are increasingly serving as motion-control systems for their vehicles. Whether you’re planning to speak, attend, or exhibit, we look forward to seeing you in Novi!

# cti symposium

8 & 9  
DEC  
2026  
BERLIN

## DRIVING TOMORROW – AUTOMOTIVE POWERTRAIN & MOBILITY REDEFINED

### MEET THESE KEY SPEAKERS

**Dr Jürgen Guldner**  
General Programm Manager  
Hydrogen, BMW AG



**Pradeep Thimmaiyan**  
Global Head of Chassis  
Technology, Product  
Engineering,  
Daimler Truck AG



**Sander Robin Kuiken**  
Senior Manager of Vehicle  
Dynamics, Volkswagen do Brasil



**Lars Johansson**  
SVP Truck Technology, Volvo  
Group Trucks Technology



**Matthias Zink**  
CEO Powertrain &  
Chassis, Schaeffler AG



**Lukas Walter**  
COO Engineering, AVL List GmbH

An event by

**Handelsblatt**  
III MEDIA GROUP

Detailed Information  
[www.cti-symposium.world](http://www.cti-symposium.world)

